



RCM-30 Refrigerant Module

Installation Manual



RCM-30 (1 Ton)

Includes:
Service/Access Ports
Freeze Stat
L-Mounting Brackets

Manufactured By
Energy
Saving
PRODUCTS LTD

Refrigerant Modules (RCM)

The cooling coil comes as a module and must be installed in the vertical position on the return air side of the air handler. For return air sizes, refer to Table 3 – Return air.

Refrigerant modules come with two L mounting brackets, access port(s), and an external freeze stat*. Fig. 01 shows an installed coil assembly and how each piece is connected.

Mounting Brackets

Mounting the cooling coil to the air handler can be done with the L brackets supplied (Fig. 02), ensure that no screws puncture the drain pan or coil. Appendix B has the dimensions of the air handler units and cooling modules.

***IMPORTANT:** The Freeze Stat (anti-ice control) serves the purpose of preventing severe icing of the coil in the event of an undercharge or low load on the coil. This piece of equipment must be used at all times. Failure to properly install the freeze stat will result in RCM related warranty issues being voided.

NOTE: Do not remove protective bubble wrap from Freeze Stat

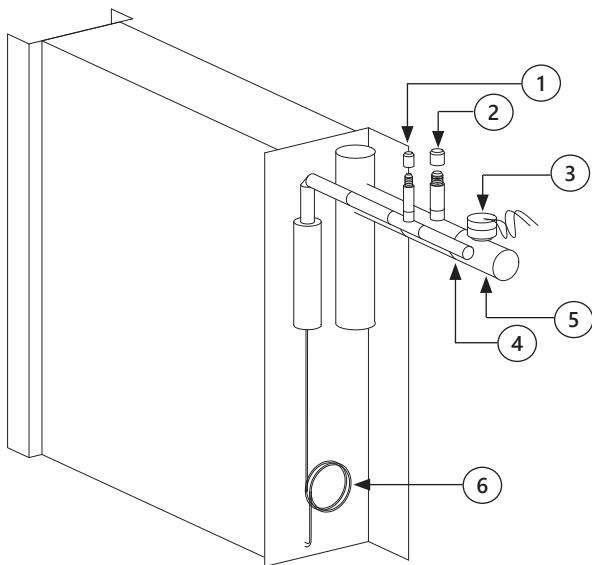
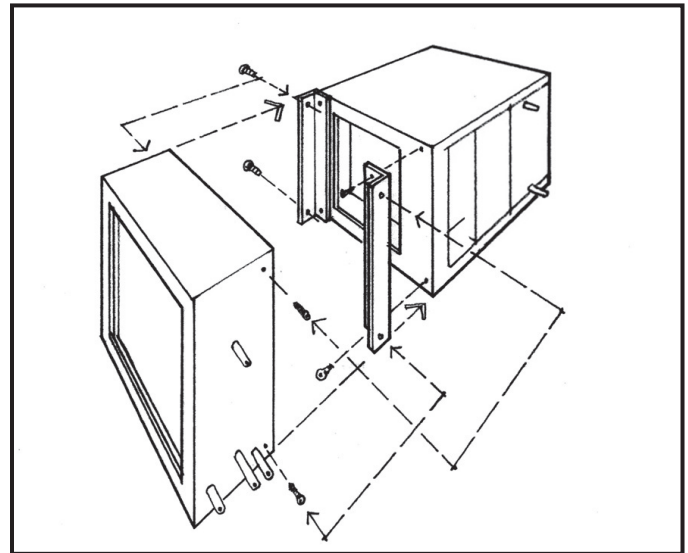

Fig. 01 - Coil Assembly

1) High side access port (if applicable)	4) Liquid line
2) Low side access port	5) Suction line
3) Freeze Stat (Anti-ice Control)	6) Capillary tubes

R series modules can be used on R-410A condensers; if R-410A refrigerant components are used. All Energy Saving Products R Series modules are shipped with R-410A refrigerant components.

Fig. 02 - Mounting Brackets



Access Ports

When refrigerant lines are connected to the air handler, access port(s) need to be installed. (Fig. 01 – reference 1 & 2). The access port(s) are required for system startup and for future trouble shooting or service.

Freeze Stat

The RCM Series cooling module comes with a freeze stat (anti-ice control). This freeze stat serves the purpose of preventing severe icing of the coil in the event of an undercharge or low load on the coil. **NOTE: Do not remove protective bubble wrap from Freeze-Stat.**

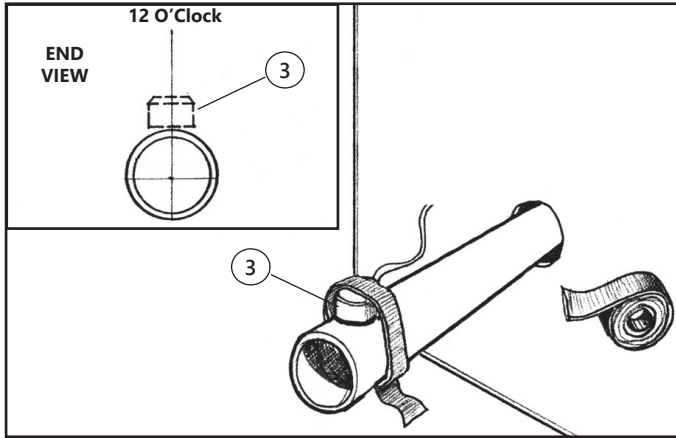

Fig. 03 - Anti-ice Control (Freeze Stat)

Install the anti-ice control (Freeze-Stat) above the center line of the suction line and connect the wires to the Freeze Stat terminals on the air handler circuit board (Fig. 01 & Fig. 03 - reference 3).

Ensure that the anti-ice control is fastened securely and is well insulated. Do not use a self-tightening clamp on the anti-ice control, as the control may be damaged by excessive tightening.

Important: The Freeze Stat (anti-ice control) must be used at all times. Failure to do so may void warranty.

Drain Connections, P - Trap & Secondary Drain Pan

Important: Piping the condensate lines on a return side cooling coil can be dramatically different, be sure to read the following info.

The primary condensate drain **must have a minimum 3" P-Trap installed** (Fig. 05). The drain line must run at a slope of 1/4" per foot in the direction of the drain. RCM-30 modules come with a 3/4" male CPVC primary and secondary outlet. It is good practice to install a clean out right above the P-Trap. Using a "tee fitting" and cap in the P-Trap's construction can be used as the clean out and as a way to prime the P-Trap if it ever dries out. A wet P-Trap is important. A dry P-Trap can be detrimental to proper drainage. If code requires a secondary drain line, run the secondary line using the same method as primary. Otherwise, capping off the secondary drain line is acceptable. Do not run the secondary drain line to the secondary drain pan or use it as a vent to atmosphere! An equipment stand/riser or rubber equipment mat may be necessary to elevate the module off of the ground to allow for a P-Trap.

Any installation that has the potential of property damage due to condensate must have a secondary drain pan installed. If the unit is installed in a high heat and/or high humidity location, extra insulation around the unit casing may be required. This will prevent excessive condensate from forming on the outer surface of the casing.

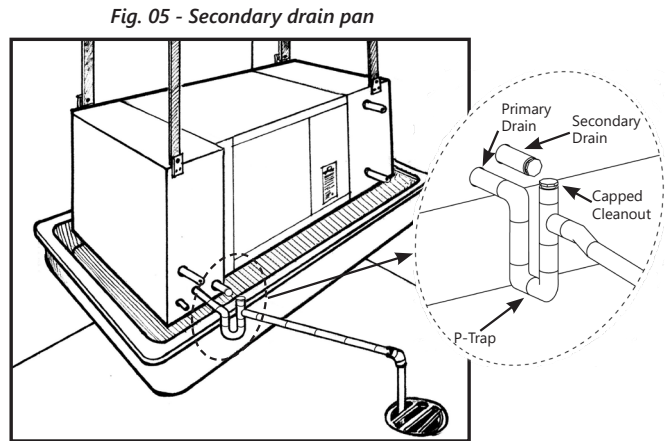

Piping the RCM

Only refrigerant grade pipe and fittings are to be used with Hi-Velocity Systems. Plumbing fittings may contain wax or other contaminants which are detrimental to the proper operation of the system. Insulate the suction line with 3/8" insulation such as Armaflex. In high heat areas, 1/2" insulation may be needed. If the lines are run in an area where temperatures could exceed 120°F or runs longer than 50', then the liquid line may need to be insulated as well. Support the pipe every 5 feet, or whatever local code states.

Run the pipes in the most direct route possible, taking into account structural integrity and building details. If the evaporator is located above the condenser, slope any horizontal runs toward the condenser. If the condenser is located above the evaporator, a P-trap must be installed at the bottom of the vertical riser. For long vertical risers, additional P-traps must be installed for every twenty feet. For lines running over 50', a suction line accumulator must be installed. Lines running over 100' are not recommended.

Pipe Sizing

Tables 01 and 02 contain line sizing information for the liquid and suction lines.

Table 01 – Liquid Line sizes	
	Tons
Distance	1
1'–25'	¼
26'–50'	5/16
51'–75'	¾
76'–100'	¾

Table 02 – Suction Line sizes	
	Tons
Distance	1
1'–25'	5/8
26'–50'	¾
51'–75'	¾
76'–100'	¾

The sizes given in the above tables are only for general reference, if the condenser manufacture requires a different size than specified in **Table 01** and **Table 02**, their sizing shall be used whenever a discrepancy occurs.

Outdoor Unit Installation

Locate the outdoor unit in a suitable location, as close as possible to the air handler. Maintain the clearances recommended by the manufacturers of the outdoor unit, to ensure proper airflow. The outdoor unit must be installed level, in a properly supported location. A liquid line filter/drier is recommended to be installed.

Wiring – Outdoor Unit

Make all connections to the outdoor unit with rain tight conduit and fittings. Most building codes require a rain tight disconnect switch at the outdoor unit as well (always check local codes). Run the proper size copper wires to the unit, and connect as per the manufacturer's recommendations.

Evacuating

After the piping is installed and all components have been brazed together, a vacuum pump must be used to evacuate the system from both the low and high side to 1500 microns. Add pressure to the system to bring the pressure above zero psig. After allowing the refrigerant to absorb moisture, repeat the above procedure. Evacuate the system to 500 microns on the second evacuation, and ensure that the system holds at the vacuum pressure. If not, check for leaks and evacuate again. If the vacuum holds, add refrigerant to raise the pressure to 2 psig. At this point open service valves on pre-charged condensing units, or add refrigerant to the system.

The use of an electronic leak detector is recommended, as it is more sensitive to small leaks under the low pressures.

Charging

Once the system has been determined clean and ready for charging, refrigerant can be added to the system. The service valves on the condenser must be open at this point. Never leave the system unattended when charging. Charge to condenser manufacturer's recommendations.

Super Heat

Super heat on Hi-Velocity Systems with the RCM Series should normally be around 8°F - 12°F. The suction line should be set at approximately 42°F.

Return Air

When sizing the return air ducts, keep in mind that if they are too small they can create noise, but if they are too large, the air handler cannot build up proper pressure. Table 03 has recommended return air sizes for round and rectangular ducts. A variance of plus/minus 20% is allowable for sizing return ducts that connect to the Hi-Velocity Systems unit.

It is recommended to install a grill that is 10 - 20% larger than specifications require, this will ensure that there is no air velocity noise at the grill. Where allowed by local codes, a single return air grill may be used. When using flexible duct for return air, use one duct size larger due to the higher friction loss.

Table 03 – Return Air	
Model	Return Air Size
31 Cube	10"Ø or 100in ² 12" flex duct

Specifications		RCM-30
Matching Air Handler		CU-31 JH-15/30
Part Number		4090200030
Tons ⁽¹⁾		1.0 Ton (3.5 kWh)
Refrigerant Type		R-410A
TX Cooling MBH ⁽²⁾		6-12 (1.8-3.5 kW)
Fin Material		Aluminum
Tubing Material		Copper
Type of Fins		.006 Al (0.1524mm)
Hydronic Connection Sizes	Liquid Line (Lq)	3/8" (9.5mm)
	Suction Line (S)	5/8" (15.9mm)
	Drain Connection	3/4" M CPVC (19mm)
TXV with Built in Check Valve & Bypass		Yes
Access Ports		Yes
Freeze Stat		Yes
Shipping Weight		17 lbs (7.7kg)
Module Size (L x W x H)		14 3/8" x 12 1/4" x 12 3/8" (365mm x 311mm x 314mm)

(1) Minimum of **four HE outlets** per ton of cooling needed. (2" Duct = Minimum **eight outlets** per ton)
 (2) Smaller condensers may be matched to the air handler when needed (match TXV to condenser size)

MBH - Thousand British Thermal Units per Hour
 TX - Thermal Expansion
 TXV - Thermal Expansion Valve

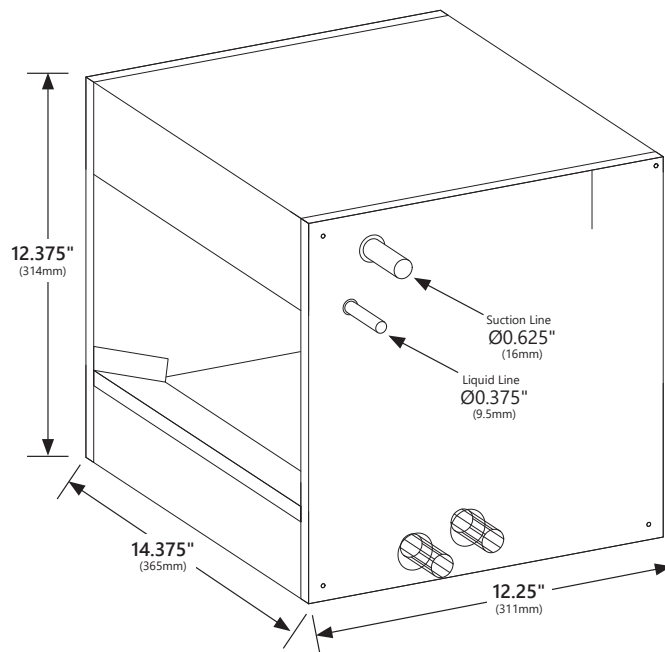

WARRANTY

Energy Saving Products Ltd. is proud to offer a limited warranty. This warranty applies strictly to the first purchaser at wholesale level and only to the Air Handler unit and module. It does not include connections, attachments and other products or materials furnished by the installer.

This warranty excludes any damages caused by changes, relocation to, or installation in a new site. This warranty does not cover any defects caused by failure to follow the installation and operating instructions furnished with the Air Handler. This warranty does not cover defects caused by failing to adhere to local building codes and following good industry standards. Failure to correctly install the Air Handler, or material related to the unit, may result in improper system performance and/or damages and will void this warranty. This warranty does not cover material installed in or exposed to a corrosive environment. This warranty does not cover products subjected to abnormal use, misuse, improper maintenance, or alteration of the product. Using the Air Handler and/or module as a source of temporary heating/cooling during construction will void this warranty.

A Five (5) Year Limited Warranty is extended on all components in products manufactured exclusively by Energy Saving Products. These components include Motors, WEG Controller, Circuit Boards, Dampers, Zoning Controls, Blowers, Motor & Blower Assemblies, Heating Coils, Chilled Water Coils, and Air Conditioning Coils. Note: If any product is installed in or exposed to a corrosive environment, warranty will be void.

A Three (3) Year Limited Warranty is extended on Electric Strip Heaters.

A One (1) Year Limited Warranty is extended on replacement parts.

Products sold by Energy Saving Products but manufactured by others, will carry the original manufacturer's warranty.

TERMS & CONDITIONS

- **Warranty will not be considered unless a contractor has contacted Energy Saving Products Ltd. Technical Support department for assistance, and received a tech code.**
- Any repair performed under warranty must be approved by Energy Saving Products Ltd. for this warranty to be valid.
- The liability of Energy Saving Products Ltd. is limited to and shall not exceed the cost of pre-approved replacement parts.
- This warranty does not cover shipping costs to and from the factory, labor costs or any other cost associated with the installation of the replacement part.
- Inoperative parts must be returned to Energy Saving Products Ltd. with an ESP RMA Form that includes model, serial number, and a detailed description of the entire problem. Inoperative parts must be returned in testable condition.
- Energy Saving Products Ltd. is not liable for any other damages, personal injury, or any other losses of any nature.

Follow these steps for Service or Repair:

1. Contact the installer of the product or a licensed service company
2. Contact the distributor
3. Contact Energy Saving Products Ltd. Mon-Fri 8 am – 4:30 pm MT 1-888-652-2219

This warranty replaces all other warranties expressed or implied.

www.hi-velocity.com

Energy Saving Products Ltd, established in 1983, manufactures the Hi-Velocity Systems™ product line for residential, commercial and multi-family markets. Our facilities house Administration, Sales, Design, Manufacturing, as well as Research & Development complete with an in-house test lab. Energy Saving Products prides itself on Customer Service and provides design services and contractor support.

For all of your Heating, Cooling and Indoor Air Quality needs, the Hi-Velocity System is the right choice for you!



Small Duct Heating, Cooling and IAQ Systems

Build Smart, Breathe *Easy*

Hi-Velocity HE-Z Air Handlers, **Green** Technology



Phone: 780-453-2093
Fax: 780-453-1932
Toll Free: 1-888-652-2219

www.hi-velocity.com