



---

## HE-B Series Installation Manual

---

**HE-B-50/51**  
**HE-B-70/71**  
**HE-B-100/101**



### Features:

- Quiet Operation
- Constant Air Circulation
- Multi-Positional Air Handler
- Eliminate Hot and Cold Spots
- Easy Installation & Maintenance
- Many Attractive Vent Plate Options
- Space Saving Small Diameter Ducts

### Includes:

Hi-Velocity Air Handlers  
Heating Coils/Modules  
Cooling Coils/Modules  
Wiring and WEG Settings  
Add-ons and Options  
Product Specifications

# Table of Contents

Module INT	<b>Common Parts &amp; Introduction - Pgs. 3-5</b> Components, Benefits, Applications, Quality Assurance, Warranty Terms
Module OTL	<b>Hi-Velocity Outlet Installation - Pgs. 6-7</b> Locating and Installing Vents, Installing Rough-In Boot
Module FCP	<b>Air Handler Placement - Pgs. 8</b> Air Handler Location, Clearances, Hanging the Air Handler
Module DUC	<b>Installing Plenum and Branch Duct - Pgs. 9-17</b> Location, Connections, Duct Reductions, Flexible Duct
Module RAI	<b>Return Air Installation - Pgs. 18-19</b> Duct Sizing, Return Air Cutout, Dimensions
Module WIR	<b>Wiring and Settings - Pgs. 20-28</b> Wiring, Extended Diagrams, PSB Reference Guide
Module OPT	<b>Options &amp; Add-Ons - Pgs. 29-34</b> HWC Hot Water Coil, RBM/RCM Cooling Coils, WBM/WCM Chilled Water Coils, VESH/ESH Electric Strip Coils, Hi-Velocity Air Purification System, Fresh Air Make-Up, Fire Stopping, Humidifiers Specifications
Module DIA	<b>Diagnostics and Troubleshooting - Pgs. 35-40</b> Troubleshooting: WEG, Motor Running Too Fast, Motor Running Too Slow, Motor Not Running, 24V Htg, 24V Clg., Outdoor Unit, Short Cycling
Module SPC	<b>Specifications and Sizing - Pgs. 41-42</b> Standard, Metric, Quick Sizing Guide

# Common Parts\*

Vent Plate w/  
Removable Grill



Rough-In Boot



Elbow

Joint Connector

Plenum Duct

Connection Tee

Flexible Duct



Branch Take-Off

End Cap



Multi-Positional  
Hi-Velocity  
Air Handler



\*Example  
Configuration  
Only

Cooling Options



RBM Refrigerant Base  
Cooling Module



WBM Chilled Water  
Module

Other Options



HEPS Hi-Velocity Air  
Purification System

Heating Options

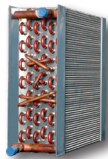

HWC Hot Water Coil



VESH/ESH Electric  
Strip Coil

## Hi-Velocity Series Installation Manual

### Thank You for Purchasing the Finest in Indoor Air Quality Systems.

The Hi-Velocity System is an energy efficient high pressure air delivery system that can be designed to provide heating, cooling, filtration, ventilation, humidification and dehumidification.

#### Ease of Installation

The Hi-Velocity System can be installed in 25 percent less time than a traditional heating system and is equally suitable for commercial and residential, in both new construction and retrofit applications. For residential applications where every cubic foot of area is critical, the Hi-Velocity System is the solution to your heating and cooling needs. Being able to run duct work into places where standard duct work would not fit, allows heating, cooling and ventilation to be installed in applications where the options are very limited.

The Hi-Velocity System works on the principle of pressure rather than air velocity. It is quite different than a conventional furnace, the main difference being that the supply duct work is all "small diameter" or "mini duct", which takes about 75% less space than conventional ductwork.

With a pressurized small diameter duct we condition the air differently than conventional forced air systems. With the use of a high pressure area to low pressure area, we continuously mix the room air, creating even temperatures from floor to ceiling. Because the plenum duct is pressurized, dust build-up within the duct work is eliminated. With continuous air circulation from the constant fan, airborne dust and other allergens can be easily filtered out of the air, and conditions that promote the growth of mold and mildew are reduced.

Our innovative air handler and unique cooling module technology helps create a healthier and more enjoyable indoor living environment for the end-user, while saving money on monthly operating costs.

Powered by a variable-speed VFD motor, the Hi-Velocity System can be used for heating, cooling, or a combination of both. The VFD motor quietly drives the system's fan continuously, limiting wear and tear and increasing the lifespan of the system.

We are confident that you will enjoy years of trouble-free service from your Hi-Velocity System. As with any product that requires installation and assembly, a good understanding of ALL the components and the final product is necessary to achieve the optimum result. This manual has been designed to be as concise and straightforward as possible.

**Please read the ENTIRE manual before beginning installation as this will help avoid mistakes that may cost time and money.**

### Primary Applications:

#### Heating Up

To provide heating, the system can be used in conjunction with DX heat pumps or any water source (hot water tank, boiler or geothermal). Unlike traditional heating and air conditioning systems, it does not depend on the natural laws of convection. A network of smaller, flexible ducts operate under high pressure to continuously circulate air and ensure even heat distribution. When using a hot water tank, after going through the heating system, the hot water is recycled for household use. With a proper tank, the Hi-Velocity System can reduce energy requirements by up to 50 percent.

#### Cooling Down

For air conditioning, a cooling module, condensing unit, chiller, heat pump or geothermal system can all be used. The high pressure distribution network cools each level of the structure evenly. Use of a lower CFM across the cooling coil means that the Hi-Velocity System can remove up to 30% more moisture from the air than conventional systems, leaving a constant and comfortable temperature on the skin surface.

#### Breathing Right

IAQ is integral to the comfort and health of a building's occupants. The optional Hi-Velocity Air Purification System (HEPS) was designed to complement the heating and cooling system. It contains three powerful technologies. First, an electrostatic MERV-13 filter removes allergens. Photo-catalytic oxidation is then used to destroy toxic chemicals and eliminate odours. Finally, Ultraviolet Light is used to neutralize germs on contact. The result is clean, purified air, and unsurpassed Indoor Air Quality for your home or office.

For all of your heating, cooling, and Indoor Air Quality needs, the Hi-Velocity System is the right choice for you!

## Quality Assurance

Air handler units shall be a total indoor air quality system complete with heating, cooling, air filtration, and possibility of humidity control and fresh air make up. The air handler must be factory manufactured, assembled and tested.

All equipment furnished under this specification shall comply with the following standards:

<u>ASHRAE</u>	American Society of Heating, Refrigerating and Air-Conditioning Engineers
<u>AHRI</u>	Air-Conditioning, Heating, and Refrigeration Institute
<u>CSA</u>	Canadian Standards Association
<u>CE</u>	European Conformity
<u>DOE</u>	Department of Energy
<u>UL</u>	Underwriters Laboratories

Refer to *Module SPC - Specifications and Sizing* for system specifications, measurements, etc. For more detailed specification pages please see our website.

[www.hi-velocity.com](http://www.hi-velocity.com)

Also available on our website:

- Installation Videos
- Promotional Video
- Engineering Specifications
- Downloadable Installation Modules
- Complete Parts List
- Complete list of Agents/Distributors
- Case Studies

**IMPORTANT:** The Hi-Velocity System is not to be used for temporary heating or cooling during the construction of the structure. **If used in this capacity all warranties will be null and void.**

## WARRANTY

Energy Saving Products Ltd. is proud to offer a limited warranty. This warranty applies strictly to the first purchaser at wholesale level and only to the air handler unit and module. It does not include connections, attachments and other products or materials furnished by the installer.

This warranty excludes any damages caused by changes, relocation to, or installation in a new site. This warranty does not cover any defects caused by failure to follow the installation and operating instructions furnished with the air handler. This warranty does not cover defects caused by failing to adhere to local building codes and following good industry standards. Failure to correctly install the air handler, or material related to the unit, may result in improper system performance and/or damages and will void this warranty. This warranty does not cover material installed in or exposed to a corrosive environment. This warranty does not cover products subjected to abnormal use, misuse, improper maintenance, or alteration of the product. Using the air handler and/or module as a source of temporary heating/cooling during construction will void this warranty.

A **Five (5) Year Limited Warranty** is extended on all components in products manufactured exclusively by Energy Saving Products. These components include Motors, WEG Controller, Circuit Boards, Dampers, Zoning Controls, Blowers, Motor & Blower Assemblies, Heating Coils, Chilled Water Coils, and Air Conditioning Coils. **Note: If any product is installed in or exposed to a corrosive environment, warranty will be void.**

A **Three (3) Year Limited Warranty** is extended on Electric Strip Heaters.

A **One (1) Year Limited Warranty** is extended on Replacement Parts.

Products sold by Energy Saving Products but manufactured by others, will carry the **Original Manufacturer's Warranty**.

## TERMS & CONDITIONS

- Warranty will not be considered unless a contractor has contacted Energy Saving Products Ltd. Technical Support department for assistance, and received a tech code.
- Any repair performed under warranty must be approved by Energy Saving Products Ltd. for this warranty to be valid.
- The liability of Energy Saving Products Ltd. is limited to and shall not exceed the cost of pre-approved replacement parts.
- This warranty does not cover shipping costs to and from the factory, labor costs or any other cost associated with the installation of the replacement part.
- Inoperative parts must be returned to Energy Saving Products Ltd. with an ESP RMA Form that includes model, serial number, and a detailed description of the entire problem. Inoperative parts must be returned in testable condition.
- Energy Saving Products Ltd. is not liable for any other damages, personal injury, or any other losses of any nature.

### Follow these steps for Service or Repair:

1. Contact the installer of the product or a licensed service company
2. Contact the distributor
3. Contact Energy Saving Products Ltd. Mon-Fri  
8am – 4:30pm MT 1-888-652-2219

**This warranty replaces all other warranties expressed or implied.**

## BEFORE YOU BEGIN INSTALLATION

A heat load calculation and duct layout is required before any installation can begin. See the Design Manual, for your unit before you begin installation. The layout is designed to provide you with the maximum benefit from your Hi-Velocity System. Small deviations may be necessary due to existing construction. However, please contact your system designer before proceeding if large deviations must be made such as:

- Elimination of a vent from a room
- Moving a vent more than 10 feet (3.05m) from it's specified location
- Re-routing the main plenum

### Outlet Installation

**A minimum of 4 (four) HE outlets or 8 (eight) 2" outlets per ton is required for all Hi-Velocity HE-B Air Handlers. Any combination of HE and/or 2" outlets can be used to meet this minimum.**

With the venturi effect of the Hi-Velocity system, you have more options in vent placement. Each vent has an effective throw of 18' (5.49m) and causes the air to constantly circulate. (Fig. OTL-01) This allows for vent placement in floors, ceilings, or walls.

Constant circulation is very important to maintain room comfort. Do not install vents under/beside/on-top of objects that may hamper the cone of influence from circulating the room air. In the event of an unavoidable obstacle, the vent plate can be equipped with our optional 15° louvered insert.

Fig. OTL-01 - Cone of Influence

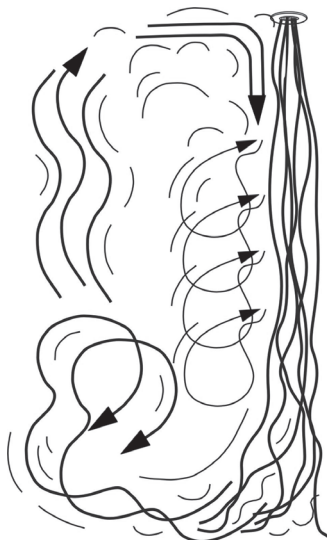
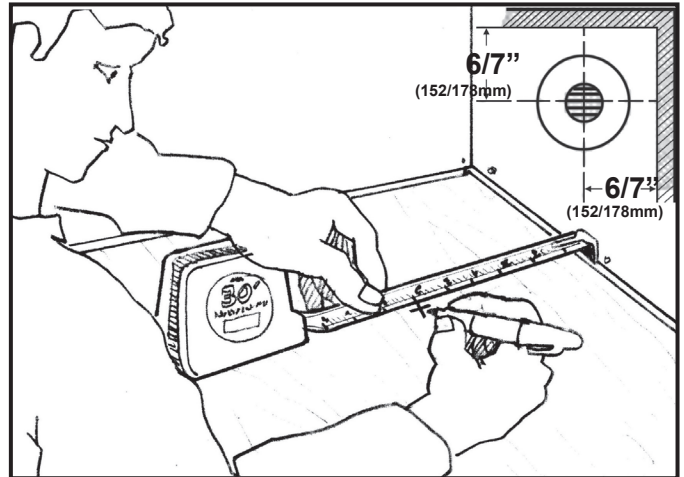

Fig. OTL-02 - Six/Seven inches (152mm/178mm) on center



### Locating Vents

Outlets do not have to be located on an outside wall. Due to the venturi action of the Hi-Velocity System, the air in the entire room is gently circulated at all times. HE outlets should be located seven inches (178mm) on centre from any possible obstruction, six inches (152mm) for 2" outlets. (Fig. OTL-02).

**PLEASE NOTE: HE flex duct outlets can not be used for 2" X 4" (51mm X 102mm) sidewall applications.**

Proper location is critical to the operation of the Hi-Velocity System for optimum home comfort. The outlets should be located where it is considered to be a "low traffic area". Typical areas are in the corner of a room, or to the side of a window or door. When the vents are properly located, the home owner can expect to have a nearly draft free home.

Vent placement in outside walls of the structure should be avoided. Flexible duct that is run in outside walls may receive a substantial heat loss/gain. This can result in a higher operating cost for the structure while delivering an inferior air quality.

## Installing the Rough-In Boot

Once a suitable unobstructed location has been chosen for the vent placement, use a 3 3/4" (95mm) hole saw to drill an opening large enough for the Rough-In Boot with a Rough-In Cap (Fig. OTL-03). For 2", use 3" (76mm) hole saw.

Before securing the Rough-In Boot, make sure to use a Rough-In Cap (Fig. OTL-04).

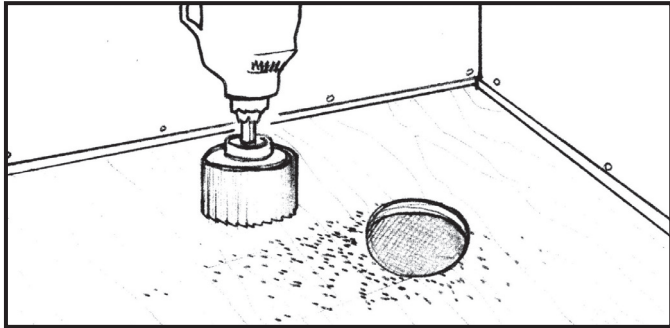

Fig. OTL-03 - Drill a 3 3/4" or 3" or (95mm/76mm) hole

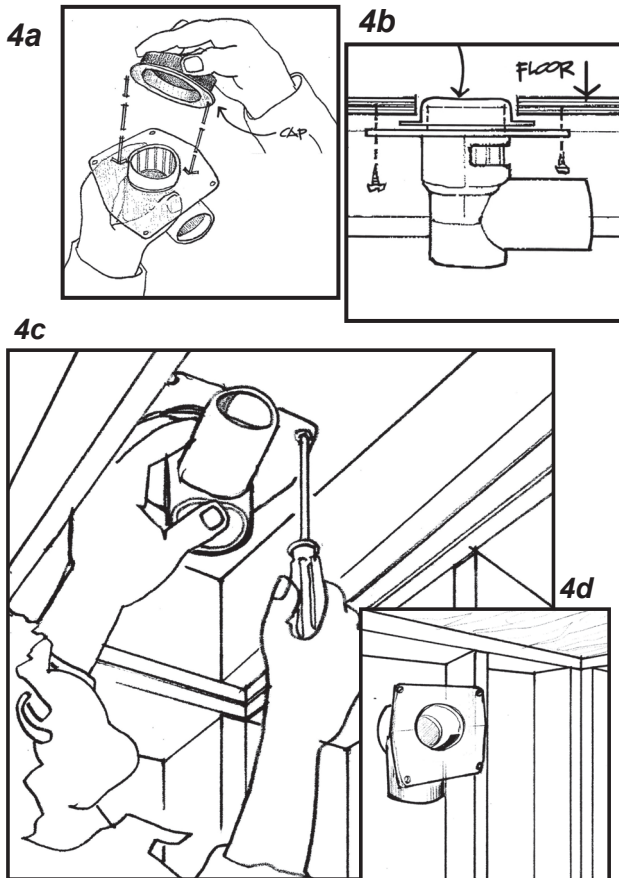

Fig. OTL-04 - Rough-In Cap Installation

- 4a - Rough-In Cap fits on Rough-In Boot
- 4b - Rough-In Boot installed with a Rough-In Cap
- 4c - Floor installed Rough-In Boot
- 4d - Wall installed Rough-In Boot

Rough-In Caps are used during construction to prevent damage during construction from drywall dust, saw dust, stipple ceiling, paint and other small particles from clogging and damaging the Rough-in Boot and Air Handler unit.

In floor applications simply place the cap over the boot before installing the boot. In ceilings or sidewall applications it may be necessary to tape the cap on to the Rough-in boot to hold into place prior to installation. To prevent damage during construction, do not cut out the Rough-In Caps until the vent plates are ready to be installed.

## Installing Vents in Kick Spaces

In kitchens and bathrooms, it is sometimes hard to find a "low traffic area", so an alternative is to locate the vents in the kick space under the counters. Our Vent plates have a 5" (127mm) diameter, which may not fit in all kick spaces without trimming. This can easily be done by trimming the top and bottom of our vent plate so it fits. HE outlets are not recommended for kick spaces.

The easiest way to install the round vent plates in the kick space is to trim off two edges of the plate. (Fig. OTL-05).

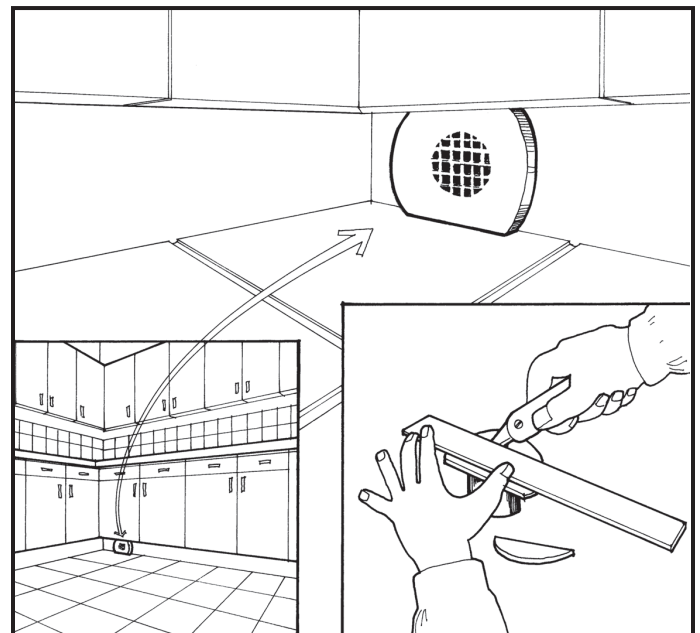

Fig. OTL-05 - Trim the edges for kick spaces

By locating the vents in this position, there will now be horizontal airflow. Caution should be exercised when locating vents in the horizontal position. Avoid placing vents directly below sinks or other locations people will be for extended periods of time.

## Air Handler Placement

The Hi-Velocity System air handler is manufactured with a direct drive permanently lubricated VFD Motor that is mounted within the blower. All Hi-Velocity air handlers are single side access. The blower assembly can easily be slid out by removing the three mounted bolts that attach it to the center plate. In some instances, the electrical box may need to be removed.

### Location

The air handler unit is to be placed according to the layout provided by the designer. As with vent placement, small deviations can be made in air handler placement. If the air handler has to be moved more than a few feet from its pre-designed location, contact the designer before proceeding.

When installing the air handler keep these points in mind.

- Serviceability and access to the unit.
- Maximizing usable floor space.
- Location of heat/cool source to air handler.

The multi-positional air handler can be installed in many different configurations. The air handler can be located in a Hi-Boy, Counter flow, or Horizontal position. In the Hi-Boy position, the supply air is delivered from the top of the unit (Fig. FCP-01).

When placed in the counter flow position, the supply air delivery is from the bottom of the unit (Fig. FCP-02).

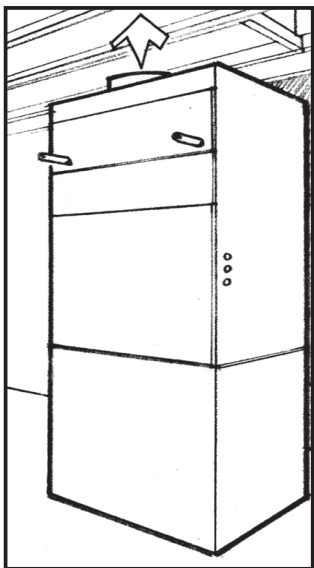

Fig. FCP-01 - Hi-Boy

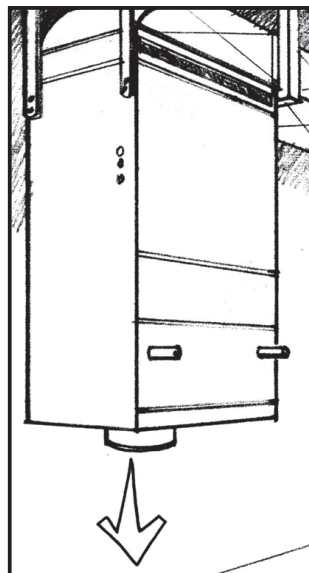

Fig. FCP-02 - Counter flow

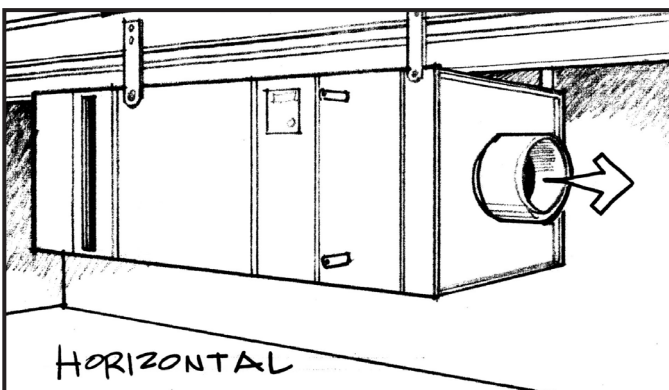

Fig. FCP-03 - Horizontal installation

Quite often, the best location for the air handler unit is suspended from the ceiling of the mechanical room, in the horizontal position (Fig. FCP-03). This will allow for more floor space in the room, and will minimize the duct work needed to connect to the air handler unit.

### Clearances

Clearance is only needed on the access side of the units. However, ensure that there is a small space between the unit and any other surface to prevent vibration transfer. In order to maintain and service the air handler unit, minimum clearances are required on the access side (Table FCP-01).

Table FCP-01 – Air Handler Clearances

Unit	Inches
50/51/52	18" (457mm)
70/71	22" (559mm)
100/101	29" (737mm)

Add an additional 4" (102mm) for Electric Strip Coils

### Hanging the Hi-Velocity Unit

The Hi-Velocity air handler can be suspended in any position, using most industry standard support systems. (e.g. Redi-rod, All thread, C-Channel, Unistrut) Check the code in your area for acceptable hanging systems. Use these in conjunction with spring or rubber isolators to ensure a sturdy hanging support system. These isolators will absorb most of the vibrations generated by the air handler system, eliminating any sound transfer.

### Securing the Air Handler to the Hanging System

In most cases when using a hanging system, fastening the air handler near the corners of the outside cabinet will be acceptable. In some cases, a bracket may be needed to secure the air handler to the hanging system.

### Hanging Air Handler Unit with Cooling Coil

Using the "L" brackets provided with the cooling coil, attach the module to the return side of air handler unit, using foam tape for air seal between units. Assure that drain connections are on the bottom (Fig. FCP-09), and that no screws puncture the drain pan or coil. The WCM and WM chilled water coils are a horizontal airflow with a vertical position of the coil while the RBM is a vertical angled coil with multiple air flow capabilities. See the corresponding manual included with the coil for detailed installation instructions.

Attach the metal flanges to the four facing corners of the air handler and cooling coil assembly.

After attaching the metal flanges, follow the same steps for hanging air handler unit only.

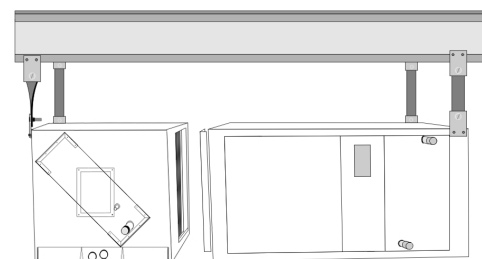

Fig. FCP-09 Attach Cooling Coil to Air Handler

## Plenum Duct

### Location

When locating the plenum duct, one of the main factors to consider is the integration of the duct work into the structure. The main supply duct can be located along the main beam(s) in the basement (Fig. DUC-01).

Fig. DUC-01 - Basement Installation

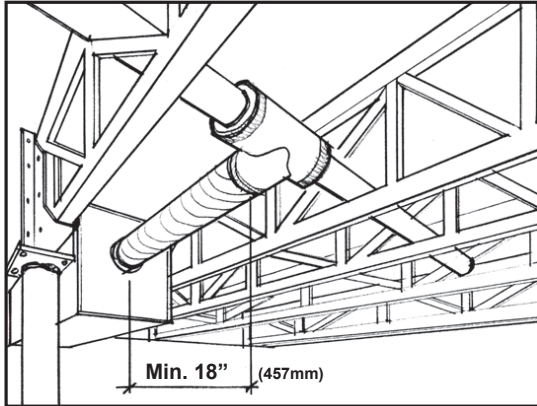

The main plenum can also be easily installed in the attic space. (Fig. DUC-02)

Fig. DUC-02 - Attic Installation

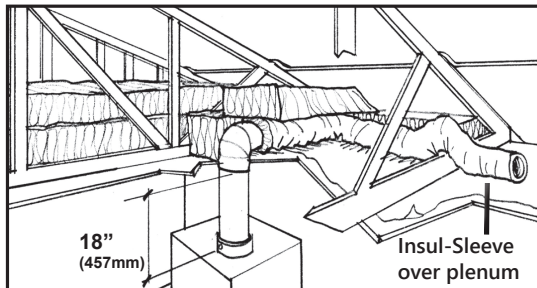

If the unit is installed in the attic, make sure that all ducts in the attic are insulated with a vapour barrier.

**All A/C systems main plenums need to be insulated and vapour barriered.**

Check with local codes for required R-Value. This includes the Branch Take-Off and the vent Rough-In Boot. All main plenum and flex runs should be installed under the attic insulation. If the duct work is run above the attic insulation, an extra insulation sleeve may be needed. Check your local building code for the ruling in your area.

**Flexible duct is NOT to be used for supply air plenum.**

For any duct runs over 75% of the maximum allowable plenum length (See Specifications Pg 42), it is recommended to insulate the main plenum. Insulating the main plenum will cut down on your duct loss, and form a vapour barrier. The attic insulation should be placed over all Hi-Velocity System ducts to further reduce any duct losses.

## Main Plenum Connectors

There are five types of connections that are possible with the Hi-Velocity System.

Fig. DUC-03 - Connectors

1. Tee Connection
2. Elbow Connection
3. Reducers
4. End Cap
5. Straight Connection

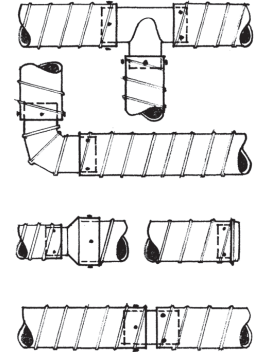

IF THE DUCT IS LOCATED IN AN UNCONDITIONED AREA, INSULATING SLEEVE IS REQUIRED ON THE MAIN PLENUM. IF USED FOR COOLING, IT IS ALSO RECOMMENDED TO INSULATE AND VAPOR BARRIER THE MAIN PLENUM AND FLEX DUCT FITTINGS. INSULSLEEVES ARE AVAILABLE AS AN ACCESSORY IN R4.2 AND R4.8 FOR 6" (150mm), 8" (200mm) OR 10" (255mm) PLENUMS IN 10' (3.05m) LENGTHS.

All of the connections are done as follows. Place the joint connector, cap, tee, or elbow inside the plenum you intend to connect. Push the plenum over the fitting as tight as possible. Use four screws on each side of the connector, alternating the screw locations as indicated in Fig. DUC-04.

Fig. DUC-04 - Alternating screw locations

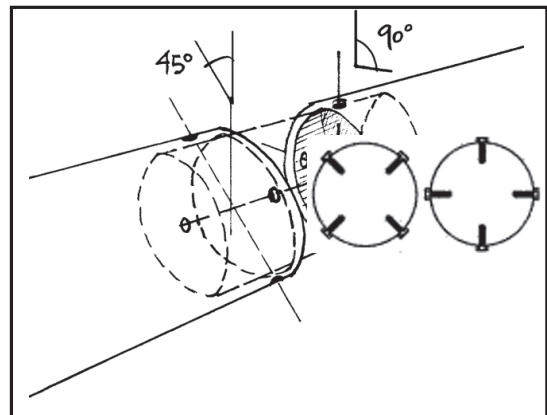

## Elbow and Tee Placement

Elbows and tees must not be placed any closer than 18" from supply outlet on the air handling unit. A significant loss of airflow can result if elbows or tees are installed closer than 18" (457mm). Figs. DUC-06 and Fig. DUC-07 illustrate a proper install with at least 18" of straight plenum after the unit supply outlet. Fig. DUC-05 shows the sigma velocity profile of the first 18" (457mm) of the main plenum and why it's important to allow the system to equalize air flow.

Fig. DUC-05 - Sigma Velocity Profile

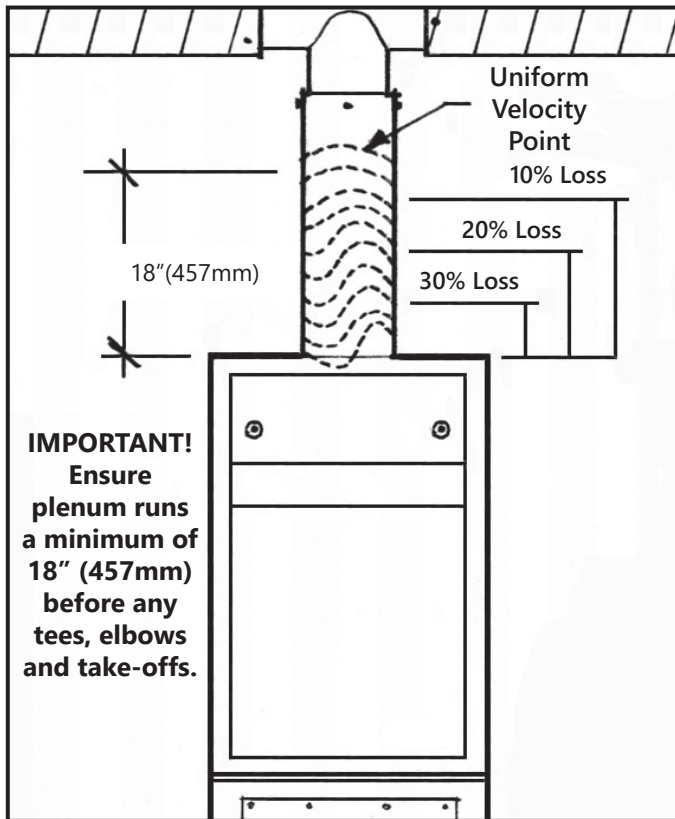

If elbows, tees, or branch take-offs are placed closer than 18" (457mm) you may lose up to 30% of your airflow as illustrated in Fig. DUC-05.

### Branch Tees

When branch tees are used, the plenum split is to be a 70/30 main/branch split (Fig. DUC-06).

Fig. DUC-06 - Branch Tee, 70/30 split

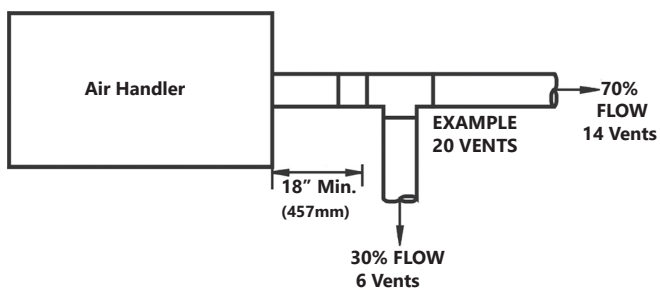
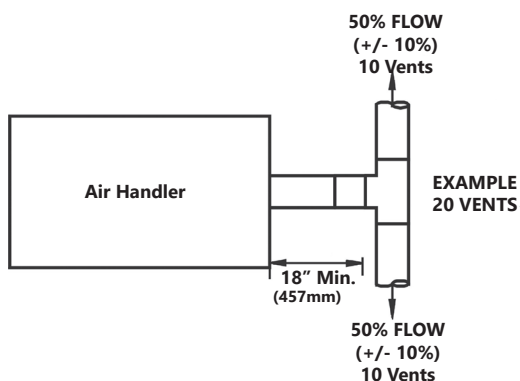

Fig. DUC-07 - Bullhead Tee, 50/50 split



### Bullhead Tees

Bullhead tees are to be maintained as close to a 50/50 split as possible, with a maximum 60/40 split (DUC-Fig. 07). For the best system performance, keep the number of elbows and tees to a minimum.

After any connection is made, including the joints of elbows and tees, foil duct tape or a duct sealant should be used to eliminate any air leaks.

Fig. DUC-08 - Seal all connections

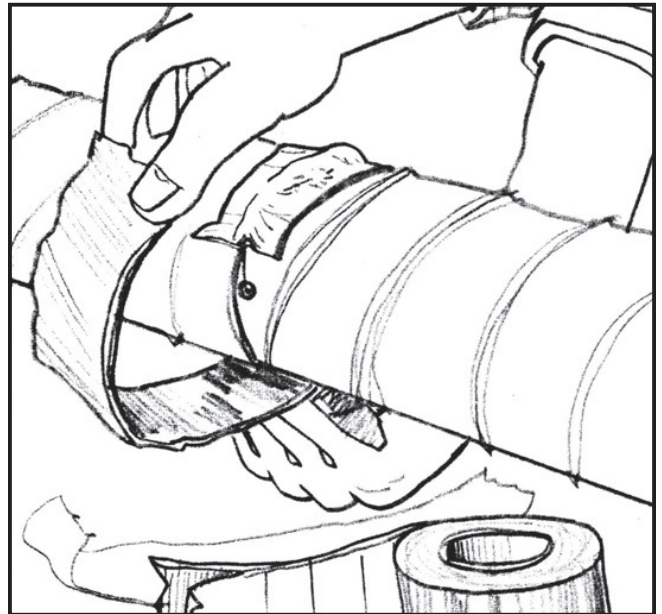

### Joist and Trusses

When running the plenum duct between joists in the basement, sheet metal strapping should be used (supplied by the installer, not the factory) to secure the plenum in place (Fig. DUC-09).

Fig. DUC-09 - Use Metal Strapping

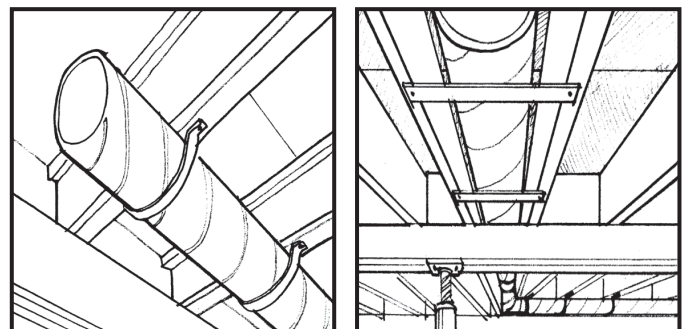

When located in ceiling spaces, the duct may be laid upon ceiling trusses. Run the duct work low so that it can be covered with the house insulation (Fig. DUC-02).

### Insulation Sleeve

Any time the duct will be run in an unconditioned space (attic or crawl space), or used in A/C mode, it must be insulated with a vapour barrier. It's also recommended to vapour barrier runs that exceed 75% of the total allowable distance (See Specifications Pgs. 42).

To install the insulation sleeve over the main plenum, either tape the end of the duct or use an end cap. This will allow the sleeve to slide on easier, and prevent the insulation from catching on the sharp metal ends of the duct (Fig. DUC-10).

Fig. DUC-10 - Use an End Cap or Reducer

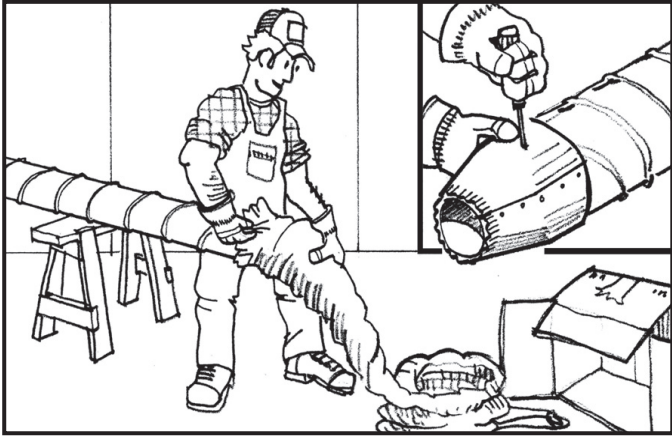

### Branch Take-Off with Insulation Sleeve

After the insulation sleeve is installed, cut an X through the vapour barrier and insulation. Peel it back enough to allow you to drill your hole without ripping all of the insulation. Install the branch take-off as described in the Branch Take-Off section. Tape around branch take-off to reseal vapour barrier and insulation.

Fig. DUC-11 - BTO with insulation sleeve



### Connecting Plenum to Air Handler

After the main plenum duct and the air handler unit are in place, they can be fitted together. Do not permanently fasten the two together yet, as the plenum may need to be rotated in order to make the branch take-off connections. Once rotated into position, fasten and seal with duct sealant or foil duct tape.

### Duct Reductions (Table DUC-01)

In some installations, it is necessary to reduce the size of the main plenum. Caution must be used when reducing plenum size, since smaller ducts can handle less number of outlets. Also, when running the plenum duct past 75% of max distance, it is best to keep full size plenum duct to reduce restriction in the main plenum. Keep in mind that once reduced, the main plenum cannot be increased again. The Branch Take-Offs form easily to ducts in the 6" (152mm) to 8" (203mm) range; extra care must be taken with smaller sized ducts to ensure a proper air seal. For tee reductions, keep the tee to the full duct size, if reducing the plenum duct, reduce only after the tee. Keep the length of the smaller duct sizes to a minimum, since the friction loss is much higher. If a hole saw will be used to drill the Branch Take-Off holes, metal ducts are recommended to be 28 gauge steel.

Table DUC-01 - Duct Reductions

Duct Size	# of HE Vents	# of 2" (51mm) Vents	Max Length
4" (102mm)	N/A	4	30' (9.14m)
5" (127mm)	3	6	40' (12.19m)
6" (152mm)	6	12	50' (15.24m)
7" (178mm)	9	18	60' (18.29m)
8" (203mm)	15	30	70' (21.33m)
10" (254mm)	25	50	100' (30.48m)

## Flexible Branch Duct

With both the Main Plenum and Rough-In Boot installed, there is now only the connection of the two. This is done with the HE or the 2" (51mm) Flexible Branch Duct. Keep in mind that the minimum duct length is 10 feet, with a maximum length of 25 feet (7.62m). Branch duct runs should be kept as short as possible to maximize the airflow through these runs. Energy Saving Products supplies the HE and 2" (51mm) flexible duct in three different configurations:

- HE x 10' (3.05m) AFD (Assembled Flex Duct)
- HE x 15' (4.57m) AFD (Assembled Flex Duct)
- HE x 25' (7.62m) UFD (Unassembled Flex Duct)
- 2" (51mm) x 10' (3.05m) AFD (Assembled Flex Duct)
- 2" (51mm) x 15' (4.57m) AFD (Assembled Flex Duct)
- 2" (51mm) x 25' (7.62m) UFD (Unassembled Flex Duct)

All configurations are available in both R4.2 and R8 R Values. The HE and 2" AFD (51mm) and come complete with the necessary components for one complete ten foot or fifteen foot branch run. The 25' (7.62m) UFD is to be used only to extend these runs if needed.

If extending branch runs longer than the minimum 10' length, contact the system designer, or reference Table DUC-02 for branch duct losses on extended runs.

Outside Diameters of Flexible Duct:

HE - R4 = 5.5" (140mm)

HE - R8 = 7.5" (191mm)

2" - R4 = 4.5" (114mm)

2" - R8 = 6.5" (165mm)

Table DUC-02 - De-rating Values

HE and 2" Flex Duct				
Tubing Length	10'	15'	20'	25'
Adjustment Factor	0%	10%	20%	35%

## HE Duct

HE Duct is designed as a direct alternative for two 2" (51mm) flex duct of the same length used in Hi-Velocity Systems. No changes are required to air handler selection and main plenum duct sizing.

HE Duct utilizes the same selecting process as the standard 2" (51mm) flex duct, a complete and comprehensive heat loss/gain must be completed in order to select air handler, plenum size, and outlet quantities. **The HE Duct is designed to directly replace two (2) standard 2" (51mm) outlets, therefore when an area requires multiple outlets, a single HE outlet can replace two of the standard 2" (51mm) ducts. Any combination of 2" (51mm) ducting, HE ducting, and drilled outlets can be used, following the minimum and maximum outlets as per unit selection.**

## Flexible Duct

Duct Size	Max CFM Output
ONE HE Duct	65 CFM (31 L/s)
TWO 2" (51mm) Flex Duct	32 CFM X 2 (15 L/s X 2)

Example: If a 3 Ton Unit has 24 outlets of the normal 2" X 10' (51mm) flex duct, you can change to 12 HE X 10' Duct outlets, or 8 HE Duct and 8 2" (51mm) Duct outlets, or any combination to give you the equivalent. See specifications Pg. 41 for Air Flow data.

## Branch Take-Offs (BTO)

The locations for the Branch Take-Offs should be determined before any drilling is done. Holes need to be a minimum of 18" from any elbows or tees. Holes need to be drilled a minimum of 7" (178mm) apart on center for HE flex, and 6" apart on center (152mm) for 2" flex. Once all spots are marked for the Branch Take-Offs, a hole saw is used to drill the outlets - 3 1/4" (82mm) for HE Branch Take-Offs and 2 1/2" (63mm) for 2" (51mm) Branch Take-Offs (Fig. DUC-12).

Fig. DUC-12 - Drill Hole

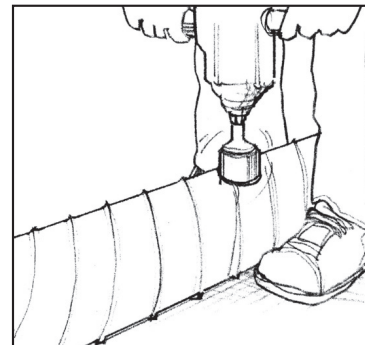

It is **NOT** recommended to connect any Branch Take-Offs until all holes have been drilled, as it may be necessary to rotate the plenum to drill the outlets.

After all the holes have been drilled in the main plenum, the Branch Take-Offs are then installed. The Branch Take-Off is placed over the hole with the gasket in between (Fig. DUC-13a). The curvature of Branch Take-Off is aligned so it matches the shape of the plenum. With the opening fully over the hole push the BTO tight against the main plenum and secure with four 1/4" (7mm) self tapping screws (Fig. DUC-13b).

Fig. DUC-13a - Branch Take-Off

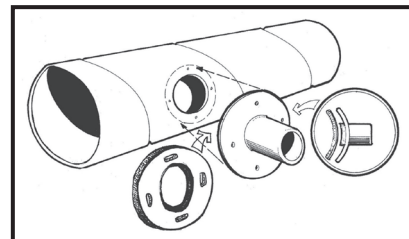
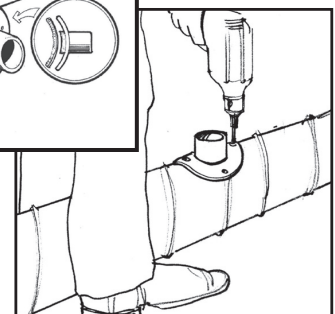

Fig. DUC-13b - Securing



## Flexible Duct Placement

After all of the Branch Take-Offs have been installed, the flexible duct can then be fastened to the joist with strapping material. Staples may be used, as long as the insulation sleeve isn't damaged or torn.

**Only use staples if local code allows.** If the insulation sleeve is damaged use foil duct tape to seal the sleeve, do not use cloth style tapes as they will not create a proper seal. Try to run the flexible duct parallel to the joists whenever possible as this takes less space (Fig. DUC-14).

Fig. DUC-14 - Use strapping to hold the Flexible duct

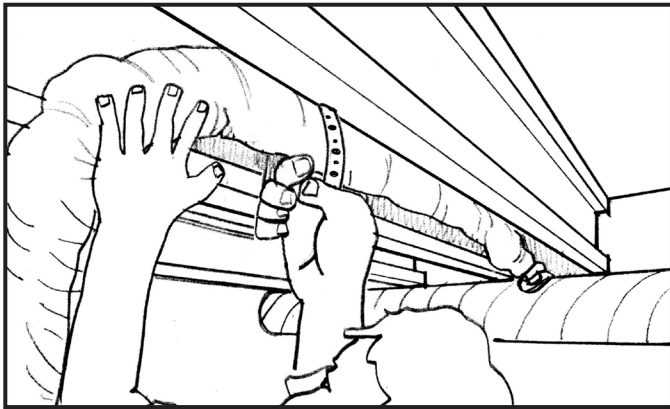

When installing the flexible duct in areas in which you must run opposite to the direction of solid joists, some drilling may be required. It is recommended to drill the smallest hole possible (Fig. DUC-15) in order to maintain structural integrity. Check with local code laws and ensure that it is allowable to drill holes through the joists before proceeding. If possible, run the flex duct under the joists and avoid drilling any holes.

Fig. DUC-15 - Through or under joists

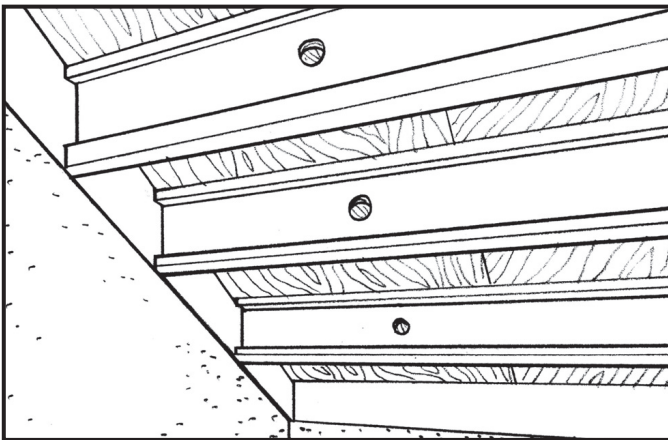

When larger holes (4"/102mm) can be drilled, then the insulated flex duct may be pulled through whole. If code or the designer only allow for a 2 3/8" (60mm) or 3" (76mm) hole, the insulation must first be removed from the flexible duct (Fig. DUC-16a). The insulation is then cut into lengths that correspond to the joist spacing. As the inner soft core of the flexible duct is fed into each hole the insulation is slid over the core (Fig. DUC-16b).

Fig. DUC-16a - 2 3/8" holes (60mm)

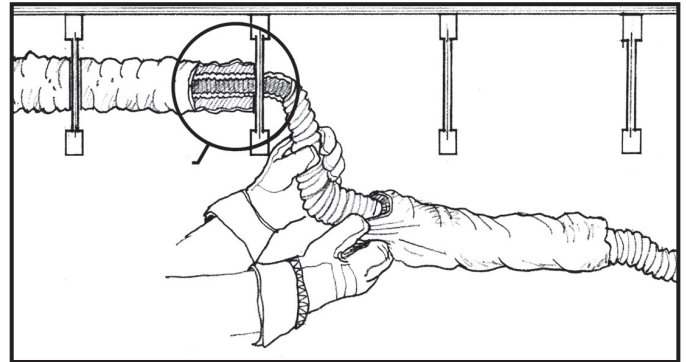
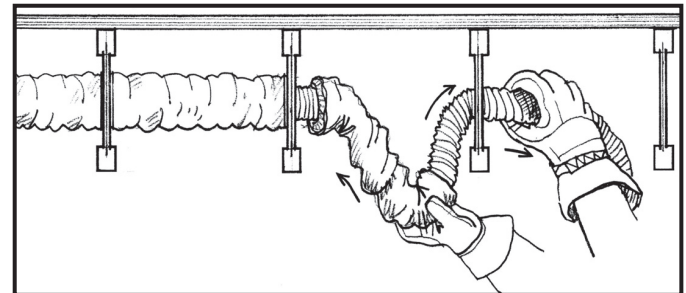

Fig. DUC-16b - Add insulation at each joist



If a T-Bar ceiling is going to be installed, it is far easier to run the flexible duct in that space, rather than drilling through several joists.

The flexible duct should never be cut shorter than 10' (3.05m) in length. If the run to the outlet is less than 10' (3.05m) the flexible duct can be coiled up. The bends in the flexible duct shall have a minimum radius of 6" or 152mm (7" or 178mm for HE Duct) (Fig. DUC-17). Sharp bends in the flexible duct will reduce airflow to that vent. Also note that runs that are perfectly straight, or stretched out too far, can also have a higher noise volume than usual.

Fig. DUC-17 - 6" (152mm) minimum radius on bends

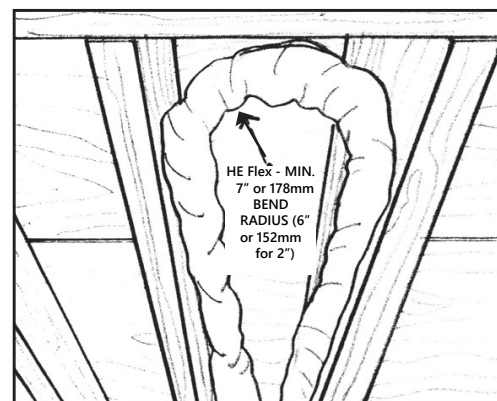

## Connecting to the Main Plenum

The Flexible Duct coupling is connected to the branch take-off, then mechanically fastened with at least one 1/4" (6.7mm) self tapping screw. The connection then should be sealed with foil duct tape or an approved sealant.

Fig. DUC-18 - Secure to plenum with gentle bends

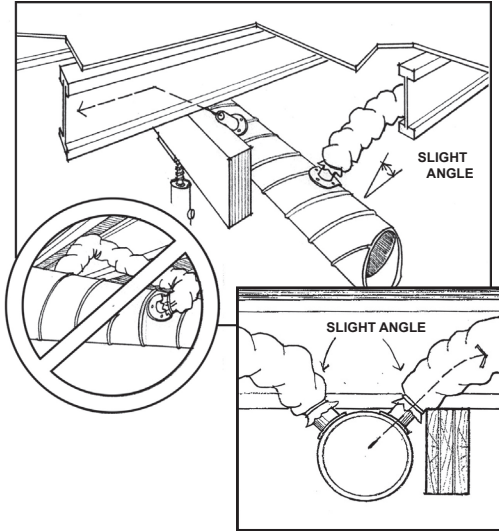

Hard angles should never be used when connecting to the main plenum or Rough-In Boot, keep the bends as gentle as possible (Fig. DUC-18). A hard bend should never be created in the flexible duct as this will restrict airflow to the outlet.

## Connecting to Rough-In Boot

The Flexible Duct coupling is connected to the Rough-In Boot, then mechanically fastened with at least one 1/4" (6.7mm) self tapping screw (Fig. DUC-19). The connection then should be sealed with foil duct tape or an approved sealant.

The Rough-in Boot can be insulated and vapor barriered using the insulation and vapor barrier that is around the flex duct. Cut the cable tie on the flex duct and pull insulation and vapour barrier over the flange of the Rough-In boot. Secure insulation and vapour barrier in place using a cable tie, tape or other means of securing the insulation and vapour barrier. Ensure that damperable boot will still turn.

Fig. DUC-19 - Mechanically Fasten

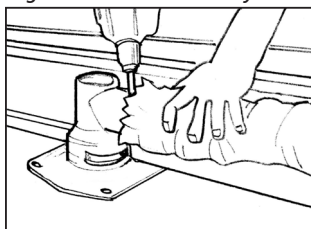

## Extending the AFD with a UFD kit

When connecting the UFD to the AFD, attach the branch coupling into the inner core of the UFD with foil duct tape, connect the two branch couplings with the branch connector tube (Fig. DUC-20). Now pull the insulation and vapour barrier over the inner core and secure around the outside of the vapour barrier with a cable tie. Tighten the cable tie securely around the branch connector, inner core, insulation, and vapour barrier.

Fig. DUC-20 - Fasten with tie straps

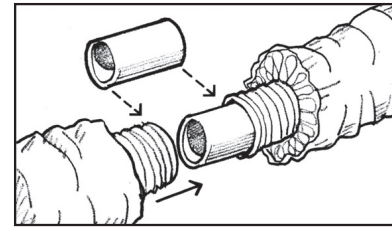

## Unconditioned Spaces

If the flexible duct is in an unconditioned space, then all connections must be taped to ensure a continuous vapour seal. This includes the Branch Take-Off and the vent Rough-In Boot. Try not to damage the vapour barrier on the flexible duct. If it is damaged, holes must be taped. If possible, try to run the flexible duct between the insulation and the vapour barrier.

## Two Inch Metal Duct

Flexible duct is not to be used in concrete applications. Caution should be used when running metal or PVC pipe under concrete, to ensure pipe is not crushed. For certain applications in which hard pipe is needed, certain guidelines must be followed. All metal ducts run in a concrete slab must be sealed with an approved duct sealer. For vertical runs out of the floor, it may be necessary to extend the damper tube or vent plate collar (Fig. DUC-23), to connect to the AFD Kit.

## Flexible Duct Termination

To complete the installation, cut out the Rough-In Cap (Fig. DUC-21) and install the vent plate by sliding the vent plate into the end of the damper tube (Fig. DUC-22). Ensure the vent is in the *fully open position*.

Fig. DUC-21

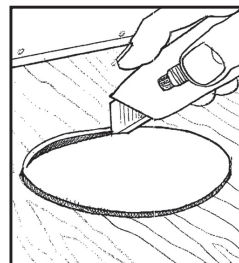
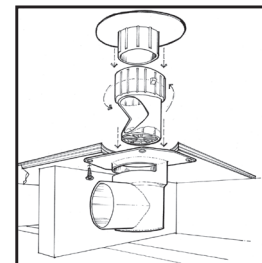

Fig. DUC-22



## Vent Plate Extensions

When the sub floor and floor finishing is too thick for the connection of the vent plate, it may be necessary to use a Vent Extender kit (branch connector tube, vent plate collar). Connect the vent plate to the connector tube, the other end of the connector tube to the collar, and attach the collar to the installed rough-in boot (Fig. DUC-23). The branch connector tube can be cut to different lengths so the vent plate sits flush with the floor finishing.

Fig. DUC-23 - Extension kit

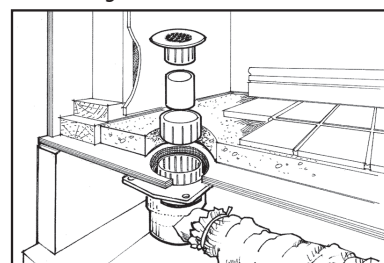

**NOTE: TEST SYSTEM FOR LEAKS BEFORE INSTALLATION OF DRYWALL.**

## Installing 2" Vents in Retrofits

For ease of installation, it is recommended to use the 2" (51mm) flexible duct and vents for retrofit applications. With the proper preparations, installing vents into finished walls and ceilings is quick and simple.

Using a 3" (76mm) hole saw, drill a hole where the vent outlet is to be placed (Fig. DUC-24). The hole needs to be enlarged in the direction of the incoming flexible duct. This is done by creating a 2 1/4" (57mm) x 1/2" (13mm) rectangle, which will allow the Rough-In Boot to slide easily into the wall.

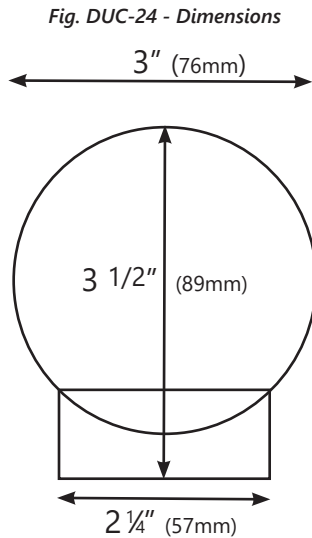

Once the hole is finished, run the flexible duct through the wall/ceiling to the vent outlet. If installed in drywall, care must be taken when pulling the flex out of the opening (Fig. DUC-25). Too much force can result in damage to the dry wall.

*Fig. DUC-25 - Run flex through opening*

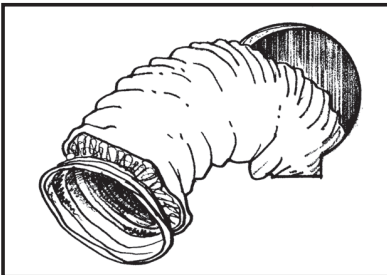

The Rough-In Boot needs a little preparation before it can be mounted to the flexible duct. The corners need to be trimmed along the score lines of each corner (Fig. DUC-26).

*Fig. DUC-26 - Trim off the 4 corners*

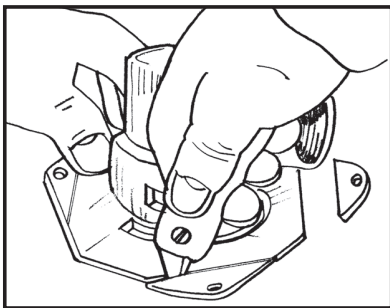

The Rough-In Boot is then connected to flexible duct and mechanically attached with a self tapping screw (Fig. DUC-27).

*Fig. DUC-27 - Secure flex to Rough-In Boot*

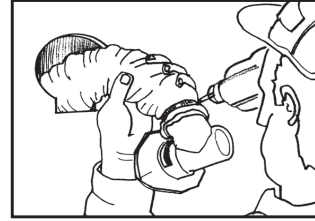

Next the flex is fed back into the wall and Rough-In Boot slid into the hole (Fig. DUC-28).

*Fig. DUC-28 - Feed the flex back into the wall*

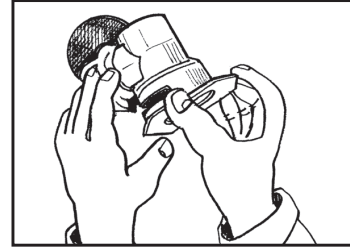

*Fig. DUC-29 - The Top*

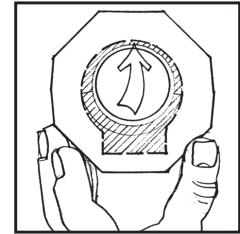

The Rough-In Boot is placed at the top of the hole; top is the opposite side of the cut out rectangle (Fig. DUC-41).

If being installed in drywall, with the boot seated firmly against the top, 3 pilot holes need to be drilled for 1/4" (6.7mm) drywall anchors (Fig. DUC-30).

In drywall applications, 3 drywall anchors (1/4" or 6.7mm) should be used to secure the Rough-In Boot to the wall (Fig. DUC-31).

*Fig. DUC-30 - Pre-drill for anchors*

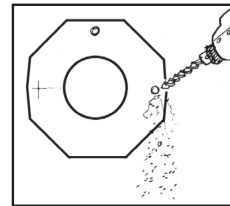

*Fig. DUC-31 - Anchors*

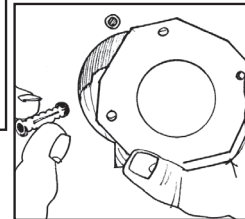

Once drywall anchors are installed, screw down the Rough-In Boot and secure it in place.

The vent plate can now be attached to the Rough-In Boot. Be sure vents are turned all the way counter-clockwise, to the fully open position.

## Linear Grills

Installations in areas that have a high heat loss/gain require multiple vents. Multiple vents can be installed into linear grills for a more esthetically pleasing look. Installing in a high sidewall/ceiling or floor makes little difference (Fig. DUC-33). A *Straight Vane* vent grill is the only type of linear grill that can be used with the Hi-Velocity System (Fig. DUC-34). Linear grills must be purchased from a third party vendor.

Fig. DUC-33 - Linear Grills

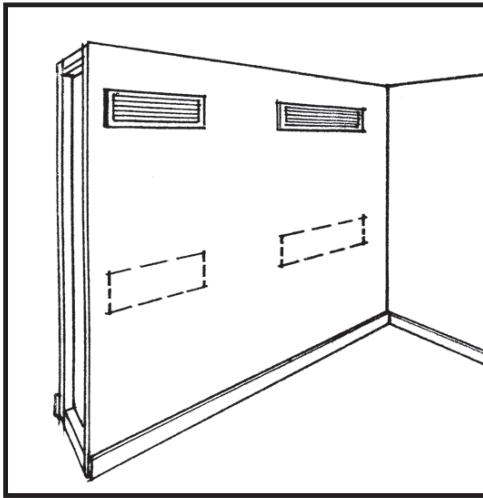

When installing multiple vents into linear grills, the 2" (51mm) vents must be a minimum of 6" (152.4mm) on center from each other, 7" (178mm) for HE vents. (Fig. DUC-35). Same rules apply for vents in linear grills as a single outlet installation; see Module OTL - Outlet Installation for more information on vent placement.

Fig. DUC-35 - 6"/7" Apart on Center (152mm/178mm)

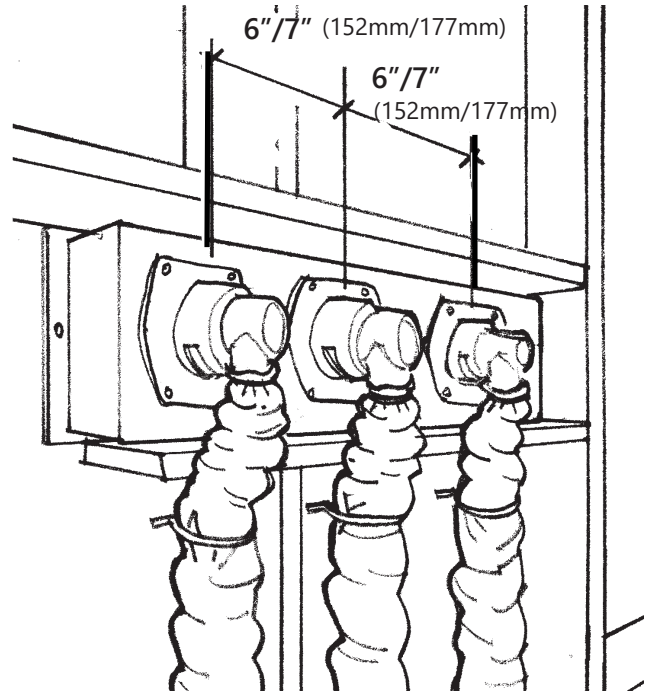

The outlet of the Rough-In Boot must be no more than 2" (51mm) away from the grill (Fig. DUC-36).

Fig. DUC-34 - Straight vanes only

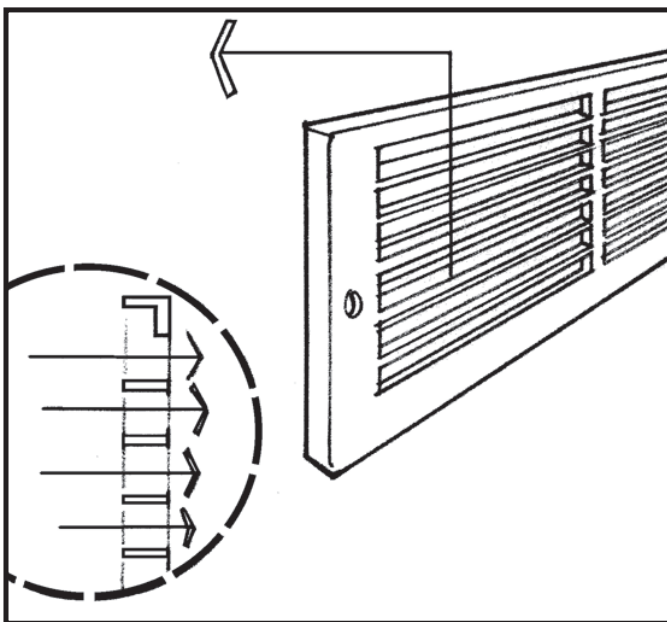
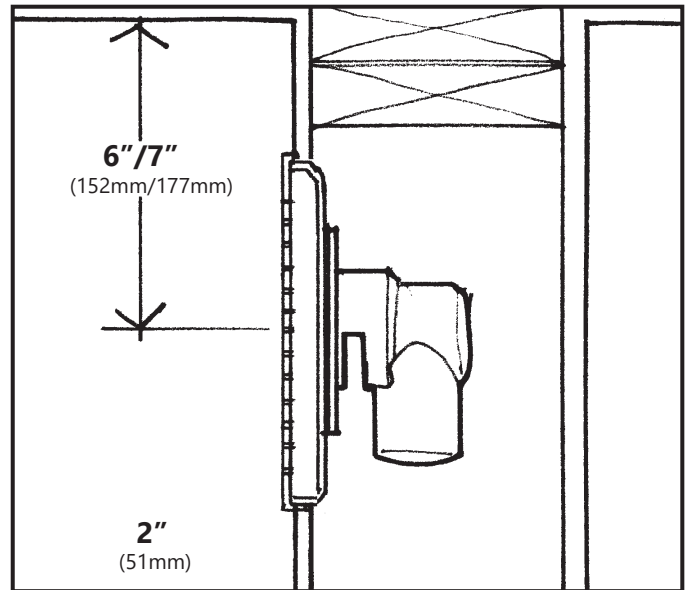

Fig. DUC-36 - Outlet no more than 2" (51mm) from grill



Installing the vents around the room will allow for the room air to mix. This will give the room a more even air temperature and better distribution.

## Drilled Outlets

Caution must be used when not using the flexible duct, the air velocity from the drilled outlet may create noise. Drilled Outlets CANNOT be installed in a residential structure; too much noise may be generated from the outlets. In commercial areas with large ceilings the sound can be absorbed by the room or is not a concern because of the ambient noises.

Drilled outlets are commonly used to supply a large area with heating and cooling. Drilled outlets can also be used to create a pressurized air curtain for bay doors, or large openings to the outside environment. When drilled outlets are used with the Hi-Velocity System a few points to remember:

- When multiple 1<sup>1</sup>/<sub>4</sub>" (32mm) or 2" (51mm) holes are used, they need to be a minimum of 6" (152mm) apart on center (Fig. 37).
- One 1<sup>1</sup>/<sub>4</sub>" (32mm) drilled hole is equivalent to a single 2"x10' AFD kit (2"/51mm Rough-In Boot attached to a 10'/3.05m piece of flex duct). With the 1<sup>1</sup>/<sub>4</sub>" (32mm) drilled outlet the throw from the outlet is up to 18' (5.49m).
- One 2" (51mm) drilled outlet is equivalent to two - 2"x10' AFD kits (2"/51mm Rough-In Boot attached to a 10'/3.05m piece of flex duct). With the 2" (51mm) drilled outlet the throw from the outlet is up to 30' (9.14m) in distance.
- Using drilled outlets larger than 2" (51mm) is not recommended; with too large of an opening in the main plenum the static pressure may drop to an unacceptable level.

Fig. DUC-37 - 6" (152mm) Apart on center

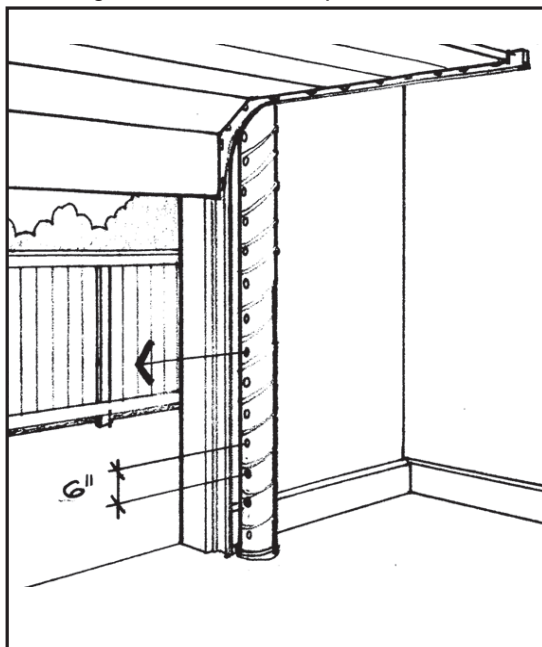

## Plenum Runs on Ceiling

When drilled outlets are used in a ceiling install, drill the outlets at a 45° angle to properly circulate the room air (Fig. DUC-38).

Fig. DUC-38 - Airflow 45° angle to floor

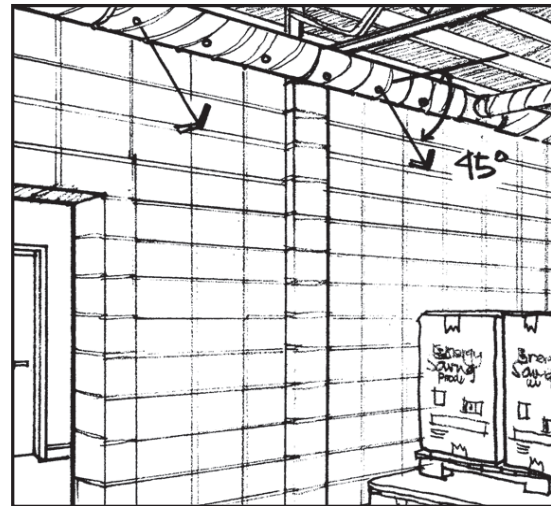

## Plenum Runs on Sidewall

For sidewall installations the outlets are drilled parallel to the floor (Horizontal airflow). When the vents are in this configuration, they can be used to create a pressurized air curtain.

Fig. DUC-39 - 6" (152mm) Airflow parallel to floor

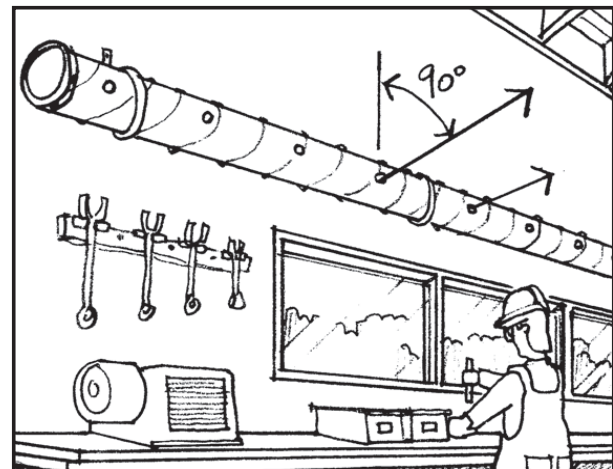

If there is an air velocity noise coming from the drilled outlets, a static pressure reading from the plenum duct should be taken. This reading is to be taken no closer than 18" (457mm) from supply air outlet of air handler. Static pressure readings are taken from the inside edge of the plenum; do not insert pitot tube deeper than 1/4" (6.7mm) from the inside surface of the plenum.

If the static pressure is high, drilling more holes into the main plenum will lower the static pressure and the noise level of the system. The standard supply pressures for the Hi-Velocity System runs between 0.7"H<sub>2</sub>O (174 pa) and 1.2"H<sub>2</sub>O (299 pa). Do not allow the static pressure to drop below 0.7"H<sub>2</sub>O (174 pa) as this can cause a low airflow.

## Return Air

When designing the return air for a Hi-Velocity System, there are a few things to consider. It is common to use centralized return air with systems that have rooms that are within a common area. Separate floors or rooms that have high loads and require a large amount of supply air flow should have their own return air, or be tied into the centralized return air to allow the air to return back to the air handler. Rooms or areas that cannot be tied into the return air should have an air transfer grill to allow the air to escape the room and flow back to a centralized return air.

The Hi-Velocity System is a pressure supply duct system that forces the air into rooms through supply outlets. A closed room will pressurize, and air will escape through the undercut of a door back to a centralized return air. (i.e. a typical bedroom with two 2" outlets or 1 HE outlet will deliver 64 cfm into the space, a 1/2" undercut door will provide 15 square inches of r/a from the space at a transfer velocity of 4 fpm, sufficient to provide comfortable r/a.) If more than four 2" or two HE vents are installed in a room, or if there is a sealed door in the room, an air transfer grill or return air should be installed to allow the air back to the air handler.

The return air duct is not supplied with the Hi-Velocity System. It is to be supplied and installed by the contractor. The return air and fresh air make-up ducts are to be installed according to local building code.

The return air duct from the air handling units is to be acoustically lined for sound absorption, for the first five feet, or for the line of sight. This only applies on short return air duct work of less than 10 feet (3.05m).

### Duct Sizing

The return air is to be sized on a 0.15 static pressure (37 pa) as compared to 0.10 static pressure (25 pa) for conventional forced air systems. The maximum length for an individual return air duct is fifty feet (15.24m).

**Please note: It is VERY important NOT to undersize the return air, as this will create noise, increase motor power consumption and reduce airflow.**

Table RA-01 has recommended return air sizes for round and rectangular ducts. A variance of **plus 20%** is allowable for sizing return ducts that connect to the Hi-Velocity Systems unit.

Table RA-01 – Return Air Duct Sizes

Unit	Rigid Ø	Flex Ø	Min Sq. Inches (Sq. cm)
50/51/52	12" (305mm)	14" (356mm)	120 (774cm)
70/71	12" (305mm)	14" (356mm)	120 (774cm)
100/101	14" (356mm)	16" (406mm)	168 (1084cm)

Remember: When using flexible duct for return air, use one duct size larger due to the higher friction loss.

Where allowed by local codes, a single return air grill may be used. Note: Return air grill must have equal minimum of free air area to return air.

**Important: When using flexible duct for return air, use one duct size larger due to the higher friction loss.**

### Return Air Cutout

Once the placement of the return has been decided, the return air knockout(s) can be cut. (Fig. 10)

**The premeasured guide cuts supplied with the air handler should always be used to make the initial cut. After the first cut using the return air knockout(s), a metal shear must be used to maximize the return air cutout opening size.**

This allows it to match more closely to the filter, cooling coil or return air ducting size to maximize flow capacity.

Fig. RA-01 - Return air cutout

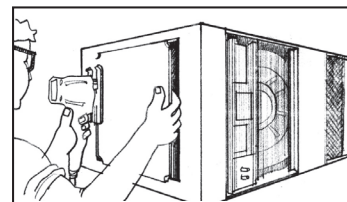

Table RA-02 – Return Air Cutout Dimensions

Model	Dimensions
50/51 H/BU	9 1/2" X 13 1/2" (241mm X 343mm)
70/71 H/BU	14" X 13 1/2" (356mm X 343mm)
100/101 H/BU	20" X 14" (508mm X 356mm)

## Return Air Cont'd

Once the return air has been cut out, a transition will be needed to attach the return air duct to the air handler (Fig. RA-03).

Fig. RA-02 – Return Air using a transition

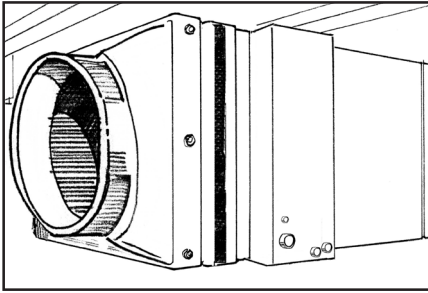

A round or square return air duct can be used; they must be sized for the Hi-Velocity Systems according to Table RA-01. Before the return air can be attached to the transition, the first five feet (from the air handler) is to be acoustically lined for sound absorption.

## Return Air Base

Energy Saving Products manufactures a return air base that matches up to the air handler units.

The return air base provides a stand for the air handler when placed in vertical orientation, and provides an easy mounting location for modular coils and filter racks. It can also be used as a transition and mixing box for the return air. All return air bases come acoustically lined with half-inch sound absorbing insulation.

For filter options and other Add-Ons available from Energy Saving Products, see Module OPT - Options and Add-Ons.

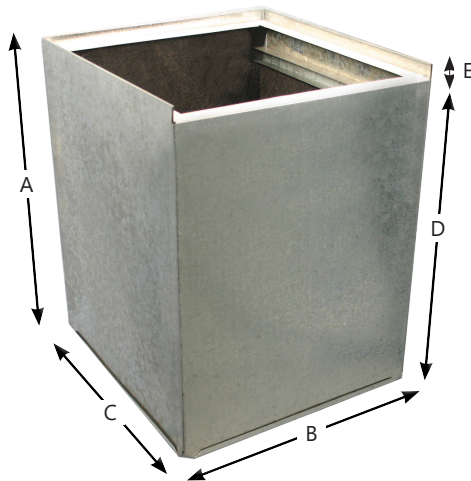

Fig. RA-03 – Hi-Velocity Return Air Base

## Return Air Base Dimensions

	A	B	C	D	E
RA-50/750	22½" (572mm)	18½" (470mm)	14½" (368mm)	21½" (552mm)	1" (25mm)
RA-70/1050	22½" (572mm)	18½" (470mm)	19½" (495mm)	21½" (552mm)	1" (25mm)
RA-100	22½" (572mm)	18½" (470mm)	25½" (648mm)	21½" (552mm)	1" (25mm)

For installation of Heating and Cooling Add-Ons, Refer to:

- Module RBM - Refrigerant Module Installation
- Module WBM - Chilled Water Coil Installation
- Module WCM - Chilled Water Coil Installation
- Module HWC - Hot Water Coil Installation
- Module ESH - Electric Strip Coil Installation

These manuals are included with the coils, and are also available online at [www.hi-velocity.com](http://www.hi-velocity.com).

## Mounting Additional Components

When mounting additional components onto the back of the unit, (Filter Rack, Return Air Base etc.) the hex head (a) screws (4 or 6 depending on unit size) can be replaced with flat head (b) screws for a flush fit.

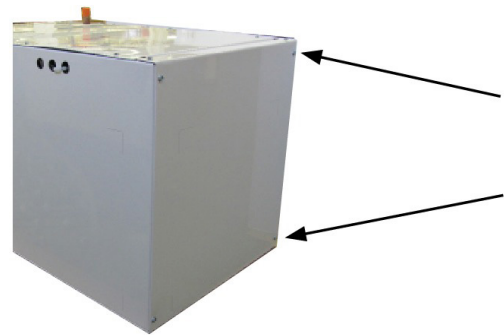

## Hi-Velocity Systems HEB Circuit Board

The Hi-Velocity HE-B Series Air Handler utilizes our HEB Circuit Board. This circuit board manages thermostat calls and makes wiring in components (i.e. Boilers & Condensers) simple.

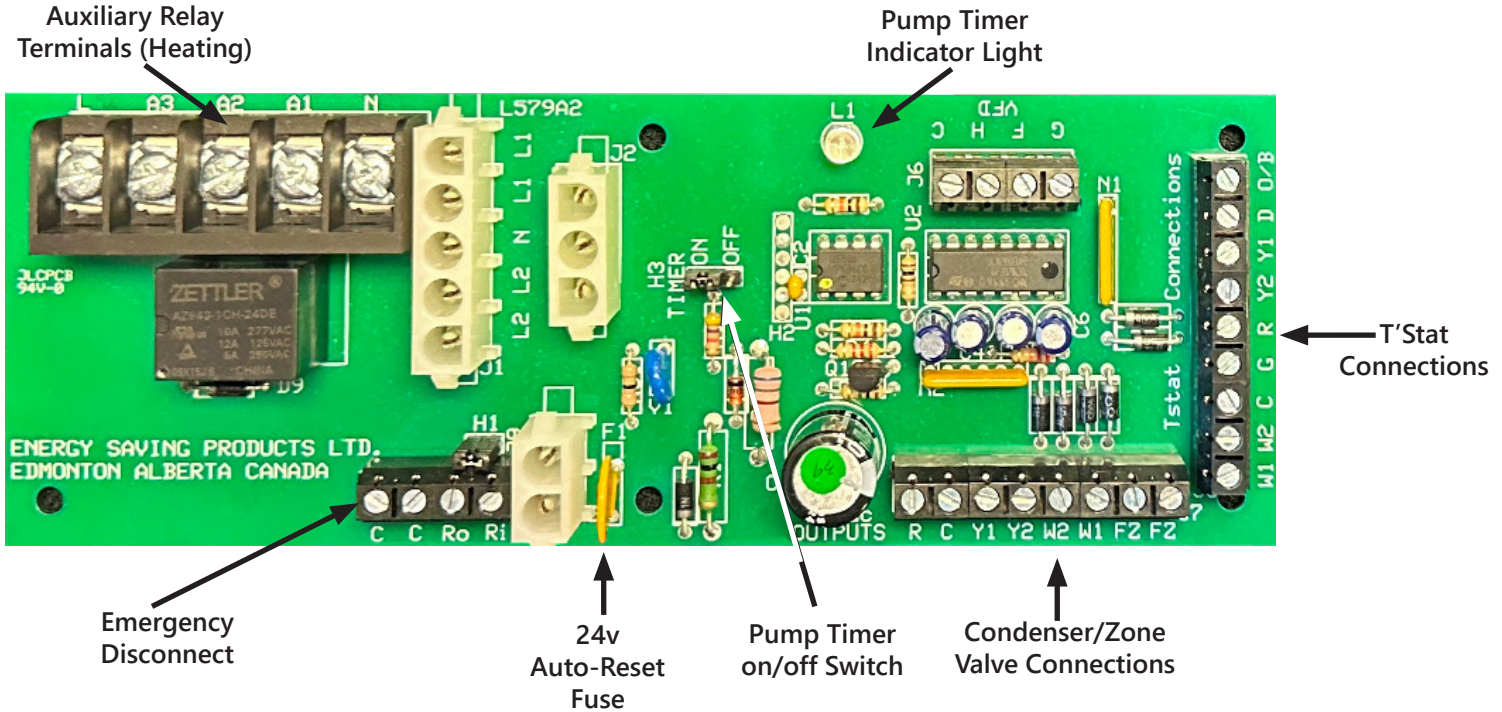

### Features:

- Wiring the circuit board is a quick and simple task.
- Clearly labeled connections.
- No additional relays typically required.
- Circuit Board manages thermostat calls and puts out appropriate control signals to the WEG VFD to initiate fan speed.
- Circuit board is capable of controlling boilers, dual purpose hot water heaters, heat pumps, and geothermal systems, as well as our manufactured slide-in electric strip heaters (ESH).
- The circuit board is also designed to send control signals to cooling sources such as condensing units, chillers, heat pumps and geothermal systems.
- Circuit board features an auxiliary relay with dry contact connections, so that any applications requiring 24v, 120v, 230v or dry contacts (boilers, hot water heaters, heat pumps & humidifiers) can be automatically started when there is a call for heat.
- Circulator timer chip is provided to prevent water stagnation in potable water systems and to provide pump rotor protection for water source heating and cooling.

- If you wish to have the timer cycle operate at a specific time of day, simply turn off power to the air handler unit for ten seconds at that time, and then turn the power back on.
- If you do not need to use the timer, move the jumper header from the On pins to the Off pins and it will be disabled.
- Circuit board is equipped with an emergency disconnect feature. If there's an emergency this feature will de-energize all fan speeds and 24 volt signals.
- For this emergency disconnect feature to be active, a jumper header must be removed from the pins located close to the emergency disconnect terminal strip. (H1)

### Function:

- Manages input power and through the use of a transformer it supplies 24vac to additional equipment.
- Organizes all thermostat inputs and prioritizes them accordingly.
- Sends a control output signal to the VFD, dependent on thermostat call.

G=Ground F=Fan H=Heat C=Cool H&C=DH

# HE-B Air Handler - HEB Circuit Board/CFW300 WEG Wiring Diagram

PLEASE NOTE: CFW10 has slightly different appearance, terminals and wiring are the same.



CFW320 HE-B / LV-B / VFD

POWER INPUT: 110-127/1/50-60

- THERMOSTAT CONNECTIONS**
- R - 24 VAC OUTPUT
  - W1 - FIRST STAGE HEAT
  - W2 - SECOND STAGE HEAT
  - (OR SINGLE STAGE)
  - Y1 - FIRST STAGE COOLING
  - Y2 - SECOND STAGE COOLING
  - (OR SINGLE STAGE)
  - C - 24 VAC COMMON
  - G - THERMOSTAT FAN SWITCH
  - D - DEHUMIDIFICATION SPEED
  - O/B - HEATPUMP REVERSING
- EMERGENCY DISCONNECT**
- C - 24 VAC COMMON
  - C - 24 VAC COMMON
  - Ro - 24 VAC OUTPUT
  - Ri - 24 VAC INPUT
- AUXILIARY HEATING RELAY**
- N - NEUTRAL
  - L - LINE VOLTAGE
  - A1 - AUXILIARY NORMALLY OPEN
  - A2 - AUXILIARY NORMALLY CLOSED
  - A3 - AUXILIARY COMMON
- 24 VAC OUTPUT CONNECTIONS**
- FZ - FREEZE STAT (FOR Y2)
  - FZ - FREEZE STAT (FOR Y2)
  - W1 - HEATING (W1) 24 VAC OUTPUT
  - W2 - HEATING (W2) 24 VAC OUTPUT
  - Y2 - CONDENSING UNIT 24 VAC OUTPUT
  - Y1 - CONDENSING UNIT 24 VAC OUTPUT
  - C - 24 VAC COMMON
  - R - 24 VAC OUTPUT
- JUMPER PIN SETTINGS**
- H1 EMERGENCY DISCONNECT: REMOVE PIN IF WIRED TO EMERGENCY DISCONNECT.
  - H3 TIMER: AUXILIARY RELAY TIMER (SEE NOTES).
- LED LIGHT INDICATORS**
- LED - GREEN LIGHT, PUMP TIMER
- PUMP TIMER STATUS**
- |                |  |
|----------------|--|
| ON: (ACTIVE)   |  |
| ON: (INACTIVE) |  |
| OFF:           |  |
- 2 SECONDS

**FAN SPEED ADJUSTMENT (COOLING, HEATING OR RECIRCULATION FAN)**

- POWER FAN COIL UNIT.
- **ENSURE ALL OUTLETS ARE OPEN.**
- ENGAGE THE THERMOSTAT SETTING TO BE ADJUSTED. (COOLING, HEATING OR RECIRCULATION FAN).
- ON THE WEG - "CFW320" PRESS THE PARAMETER BUTTON (P) UNTIL THE PARAMETER LIGHT (RED) IS ILLUMINATED.
- USING THE ARROW BUTTONS SCROLL DOWN TO PARAMETER "000".
- PRESS THE PARAMETER BUTTON (P) AGAIN TO ENTER THE PARAMETER "000".
- CHANGE P 000 TO A VALUE OF "005". THIS UNLOCKS THE DRIVE AND ALLOWS YOU TO CHANGE OTHER PARAMETERS.
- ONCE PARAMETER "000" IS SET TO A VALUE OF "005" THE DRIVE IS UNLOCKED THE FAN SPEEDS CAN BE ADJUSTED VIA PARAMETERS 124, 125, 126 AND 127.

▶ 00.0 HZ IS THE MINIMUM SPEED - 66.0HZ IS THE MAXIMUM SPEED.

**Useful Parameters**

P 000	To unlock drive change value to "005"
P 002	To display Hz output
P 030 (CFW10= P 008)	Drive HeatSink Temperature
P 124	To adjust Constant Fan Speed
P 125	To adjust Cooling Fan Speed
P 126	To adjust Heating Fan Speed
P 127	To adjust Dehumidification Fan Speed

**CAUTION**  
FOR SINGLE STAGE COOLING OPERATION USE Y2 OTHERWISE THE FREEZE STAT WILL BE BYPASSED

**NOTES:**

- 1) USE THERMOSTAT FAN SWITCH TO DISABLE/ENABLE CONTINUOUS FAN.
- 2) 'C' TERMINAL ON THERMOSTAT (COMMON) IS NOT NEEDED FOR SOME THERMOSTATS CONSULT THERMOSTAT INSTRUCTIONS FOR DETAILS.
- 3) W1 AND W2 ACTIVATES AUXILIARY RELAY (A3) ON CALL AND CAN BE USED WITH A1 AND/OR A2 AS DRY CONTACTS. ARMED 24VAC FROM THE 'R' TERMINAL, OR ARMED 110V FROM THE 'L' TERMINAL.
- 4) AUXILIARY HEATING RELAY TIMER ACTIVATES CIRCUIT FOR 5 MINUTES EVERY 24 HOURS STARTING WHEN POWER IS APPLIED TO THE UNIT.
- 5) SEE INSTALLATION MANUAL FOR MORE DETAILED WIRING DIAGRAMS.
- 6) **FOR SINGLE STAGE COOLING OPERATION USE Y2, OTHERWISE THE FREEZE STAT WILL BE BYPASSED.**
- 7) FAILURE TO SET PROPER AIR FLOW AND/OR OPERATION OF THE SYSTEM MAY RESULT IN DAMAGE TO EQUIPMENT.
- 8) FAILURE TO READ AND FOLLOW ALL INSTRUCTIONS CAREFULLY BEFORE INSTALLATION COULD CAUSE PERSONAL INJURY AND/OR PROPERTY DAMAGE.
- 9) ENSURE THAT THE FILTER IS KEPT CLEAN AT ALL TIMES.
- 10) MOTOR HAS PERMANENT LUBE BEARINGS AND DOES NOT REQUIRE OILING.
- 11) WARRANTY VOID IF FAN COIL UNIT IS USED DURING CONSTRUCTION.

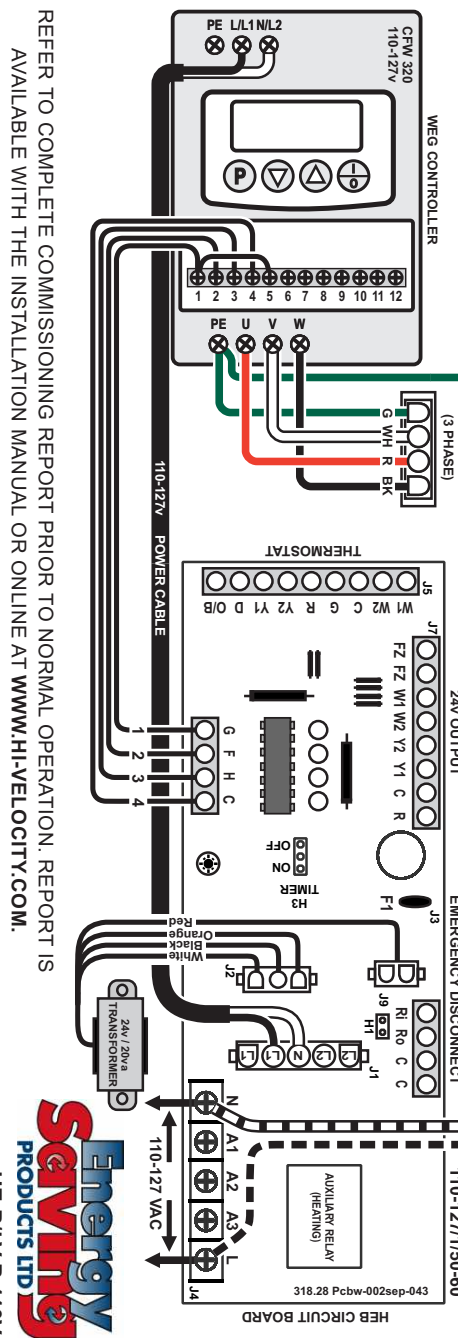

REFER TO COMPLETE COMMISSIONING REPORT PRIOR TO NORMAL OPERATION. REPORT IS AVAILABLE WITH THE INSTALLATION MANUAL OR ONLINE AT WWW.HI-VELOCITY.COM.



HE-B/LV-B 110V  
030525

## HE-B Air Handler - HEB Circuit Board Wiring

24 VAC Input terminals (tstat connections):

<b>W1:</b>	1ST STAGE HEATING, runs at the heating speed when 24v (R) is supplied.
<b>W2:</b>	2ND STAGE HEATING, runs at the heating speed when 24v (R) is supplied. The difference between a W1 call and a W2 call is the output terminal that will be energized with 24v. (W1 energized on t-stat terminal strip will provide 24v to W1 on output terminal strip, W2 energized on t-stat terminal strip will provide 24v to W2 on output terminal strip.)
<b>C:</b>	COMMON
<b>G:</b>	CONSTANT FAN, runs at the constant fan speed when 24v (R) is supplied.
<b>R:</b>	24 VOLT SUPPLY (Note: As long as transformer is connected & the Fire Disconnect/Jumper Pin Header is Present)
<b>Y2:</b>	2ND STAGE COOLING, runs at the cooling speed when 24v (R) is supplied.
<b>Y1:</b>	1ST STAGE COOLING, runs at the cooling speed when 24v (R) is supplied. The difference between a Y1 call and a Y2 call is the output terminal that will be energized with 24v. (Y1 energized on t-stat terminal strip will provide 24v to Y1 on output terminal strip, Y2 energized on t-stat terminal strip will provide 24v to Y2 on output terminal strip.)
<b>D:</b>	Runs at Dehumidification speed when 24v (R) is supplied.
<b>O/B:</b>	Heat Pump Reversing

Fan Speed Priority Sequence (from highest to lowest): D=1st Y=2nd W=3rd G=4th

24 VAC Output terminals (24v output connections):

<b>R:</b>	24 volt Supply (Note: As long as Transformer is connected & the Fire Disconnect/Jumper Pin Header is Present)
<b>C:</b>	Common
<b>Y1:</b>	1st Stage Cooling Equipment
<b>Y2:</b>	2nd Stage Cooling Equipment*
<b>W2:</b>	24v Output to 2nd Stage Heating Equipment.
<b>W1:</b>	24v Output to 1st Stage Heating Equipment.
<b>FZ:</b>	Freeze Stat Connection*
<b>FZ:</b>	Freeze Stat Connection*

**\*Note: FZ to FZ** recommended to be wired to Freeze Stat (Anti-Ice Control). For chilled water applications, a jumper between FZ to FZ must be installed to complete the Y2 - 24V Signal to Y on Condenser.

Emergency Disconnect:

<b>C:</b>	Common
<b>C:</b>	Common
<b>Ro:</b>	Provides 24VAC to the entire HEB board. In order for "Ro" to receive power it must be connected to terminal "Ri". This can be done via the two pin jumper header (H1) located above the terminal strip, a wire jumper or normally closed safety device installed between "Ro" and "Ri". <b>The jumper pin header (H1) will need to be removed to activate the emergency disconnect option.</b>
<b>Ri:</b>	Receives 24VAC direct from the transformer. Power must then be sent to the "Ro" terminal to be distributed throughout the rest of the HEB board.

3 Pin Jumper Terminals:

<b>H1:</b>	Emergency Disconnect
<b>H3 Timer:</b>	Pump timer cycles the pump on for 5 minutes every 24 hours to prevent stagnant water. (on/off) The jumper pin header (H3) will need to be in the ON position for the timer to be active.

Auxiliary Heating Relay:

<b>N:</b>	Neutral
<b>L:</b>	Line Voltage
<b>A1:</b>	Auxiliary Relay Normally Open
<b>A2:</b>	Auxiliary Relay Normally Closed
<b>A3:</b>	Auxiliary Relay Common

Control Signal:

<b>J6:</b>	4 Terminal Control Signal sending appropriate call to WEG VFD
------------	---

## HE-B Air Handler - Extended Wiring Diagrams

Extended wiring diagrams for the various applications the Hi-Velocity HE-B model can be used for. If you do not find the wiring configuration you require, please call the technical department at Energy Saving Products Ltd. for further assistance.

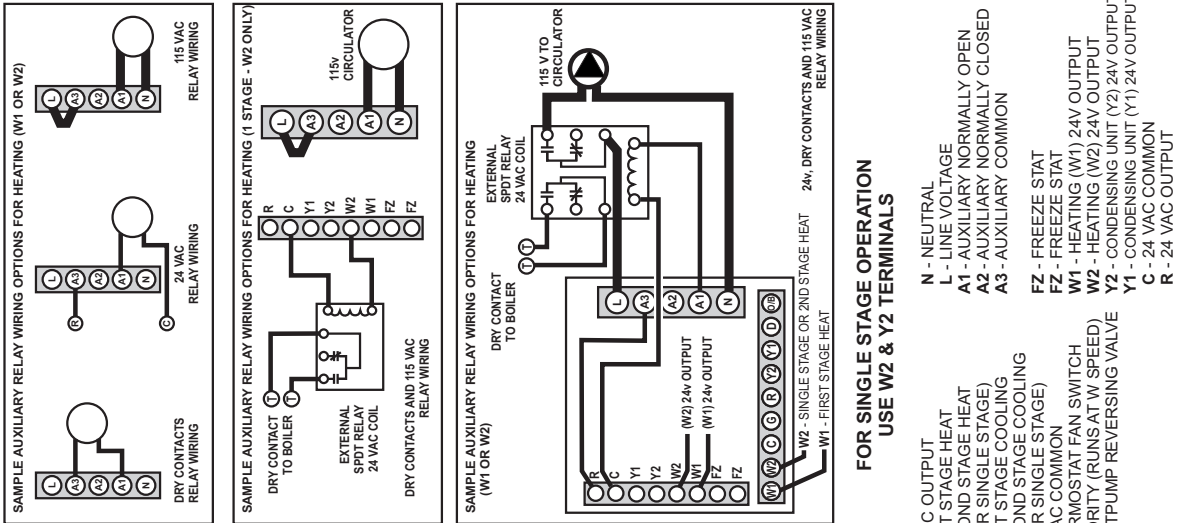

HE-B-Extended-Wiring-Pg-1-082615

**1 Stage Cooling 2 Stage Heating Heatpump**

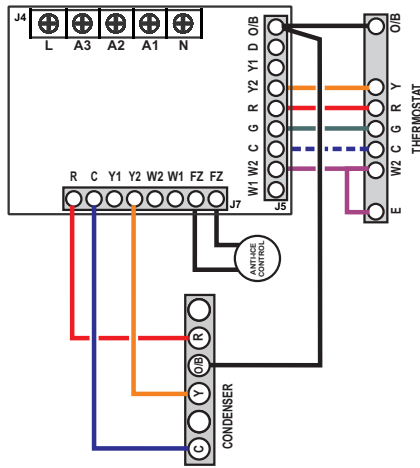

**2 Stage Cooling 3 Stage Heating Heatpump**

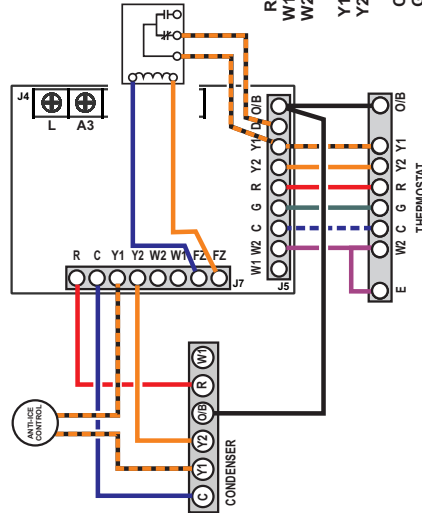

**1 Stage Cooling 1 Stage Heating**

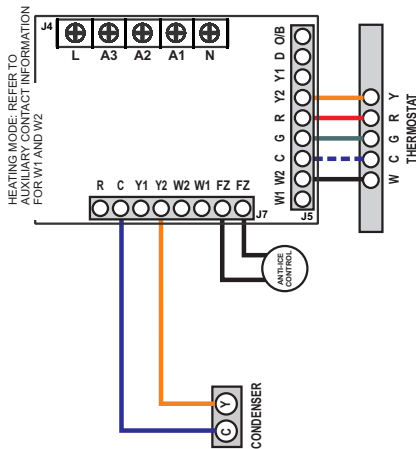

**2 Stage Cooling 1 Stage Heating**

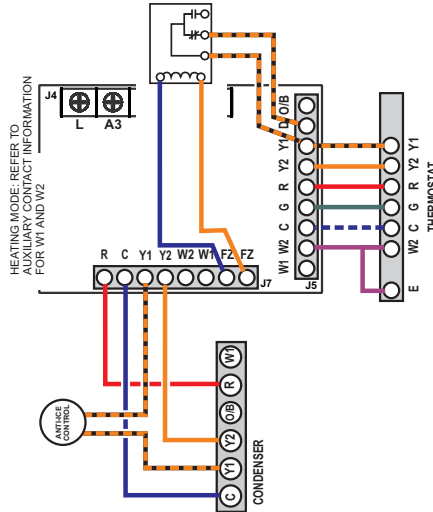

## HE-B Air Handler - Extended Wiring Diagrams

Extended wiring diagrams for the various applications the Hi-Velocity HE-B model can be used for. If you do not find the wiring configuration you require, please call the technical department at Energy Saving Products Ltd. for further assistance.

### CHILLED WATER WIRING

#### 1 Stage Cooling c/w chilled water circulator

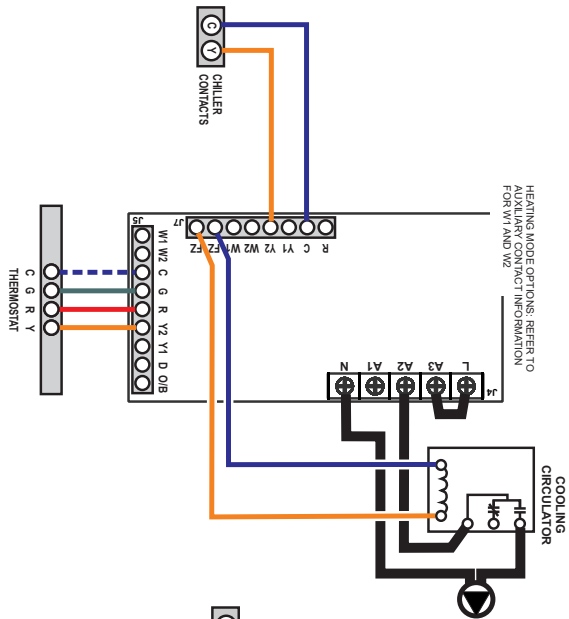

#### 2 Stage Cooling c/w chilled water circulator

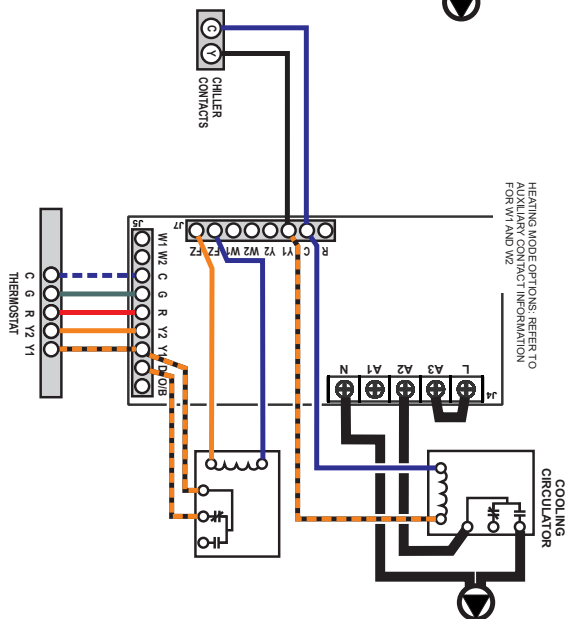

#### 1 Stage Cooling (Only) c/w chilled water circulator

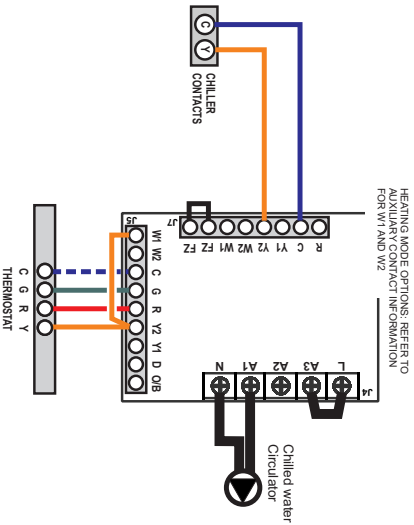

## HE-B Air Handler - Extended Wiring Diagrams

Extended wiring diagrams for the various applications the Hi-Velocity HE-B model can be used for. If you do not find the wiring configuration you require, please call the technical department at Energy Saving Products Ltd. for further assistance.

### HEAT PUMP C/W CONDENSER DEFROST CYCLE - BOILER BACK-UP

**1 Stage Cooling 2 Stage Heating**  
Heat pump c/w condenser defrost cycle

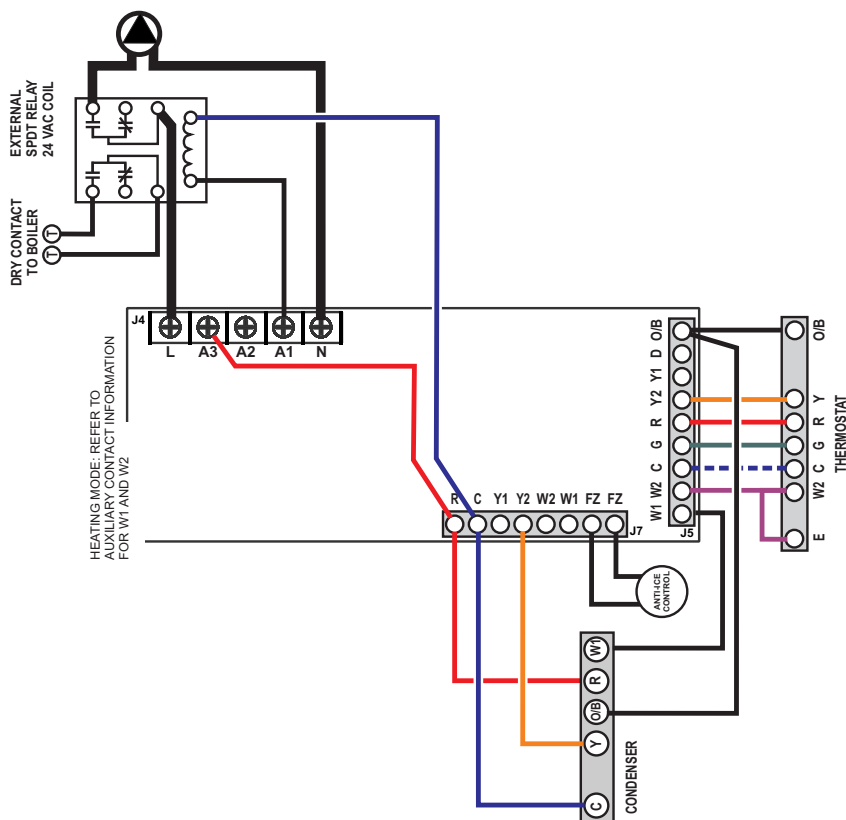

**2 Stage Cooling 3 Stage Heating**  
Heat pump c/w condenser defrost cycle

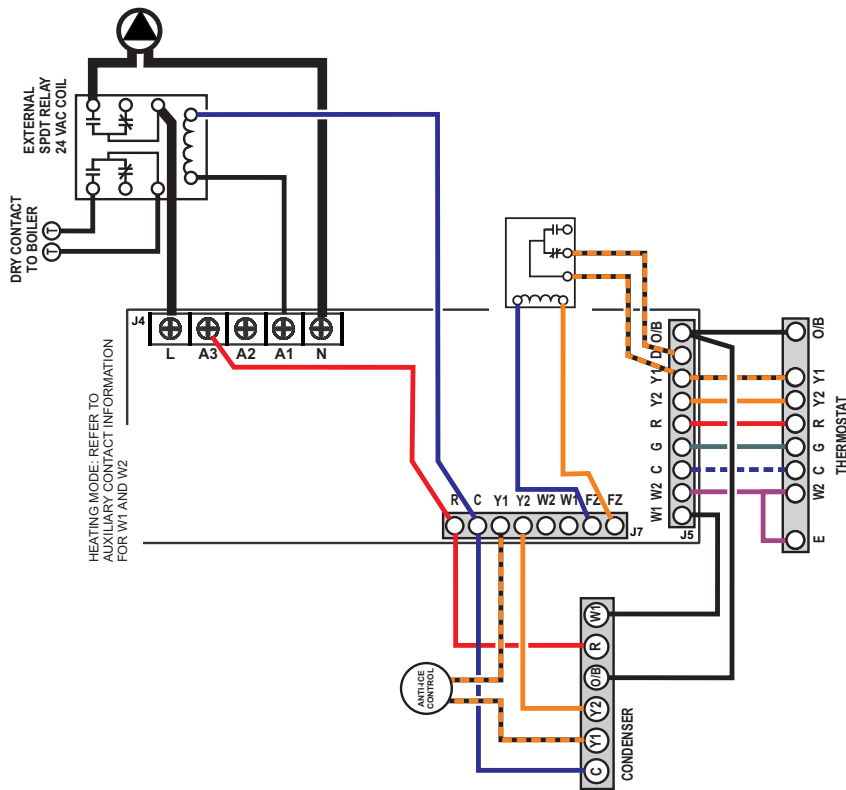

HE-B-Extended-Wiring-Pg-3-082615

## Quick Reference Guide

### Quick System Setting Reference

	Hertz Output	Outlet Velocity	Static Pressure
Cooling Mode:	55-66 Hz	1250-1400 FPM	0.8-1.2"wc
Heating Mode:	45-66 Hz	1100-1400 FPM	0.6-1.2"wc
Constant Fan:	25-35 Hz	500-900 FPM	0.2-0.5"wc

- Note:**
- Hertz will be displayed on the Variable Frequency Drive digital display.
  - Outlet velocity is based on ideal noise levels.
  - Static Pressure reading must be taken perpendicular to airflow, minimum of 18" away from supply air collar of air handler.
  - Quick references should only be used to roughly set air handler, not to be used as primary air handler set up method.

### Jumper Pin Settings

H1 Emergency Disconnect:	(Remove pin to activate)
H3 Timer:	Activates auxiliary relay for 5 minutes every 24 hours.

### CFW300 WEG - Useful Parameters

P000	To unlock drive change to 5
P002	To display Hz output
P030 (CFW10 - P008)	Drive Heatsink Temperature
P124	To adjust constant fan speed
P125	To adjust cooling fan speed
P126	To adjust heating fan speed
P127	To adjust dehumidification fan speed

### LED Description

LED 1 (Green Light) - Pump timer

See page 30 of the HE-B  
Installation Manual for fan  
speed adjustment instructions

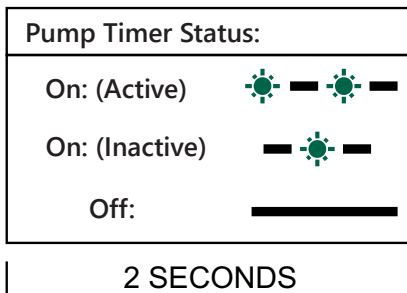
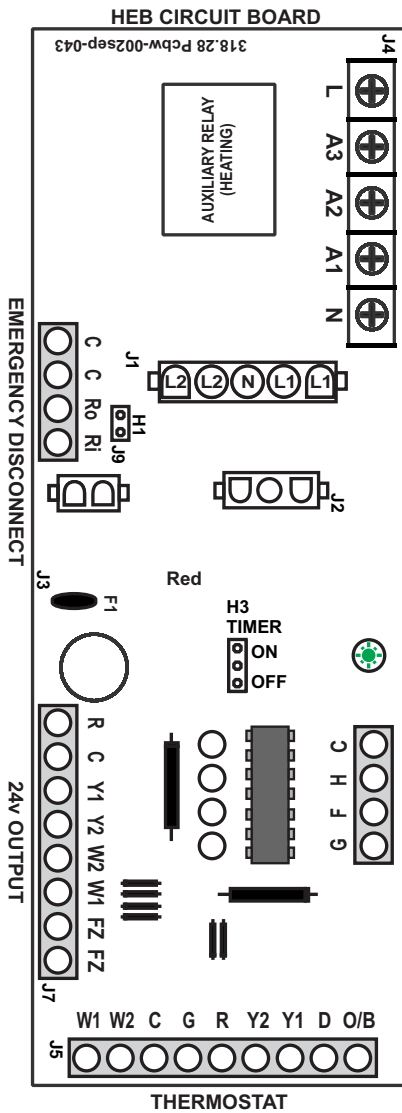

= Light On  
 = Light Off

## CFW300/320 WEG Variable Frequency Drive

PLEASE NOTE: CFW10 has slightly different appearance, terminals and wiring are the same.



The Hi-Velocity HE-B Series Air Handler utilizes a WEG Variable Frequency Drive to run its 3-phase motor. The WEG VFD is a reliable and robust motor control that will provide many years of issue free operation.

### Features:

- Purposely oversized to ensure increased reliability and higher efficiencies at peak load
- Features inherent with VFD allows for minimum power consumption at reduced loads (<100w average for constant fan speed)
- Error code read out allows for easy drive analysis in the event of a VFD fault
- Programmable drive parameters allow for acceleration and deceleration speed to be adjusted if necessary
- Digital display makes motor speed references simple
- Cooling fan in VFD Drive allows for excellent heat dissipation in high ambient environments

### Function:

- Takes single phase input (110v or 200-240v) and converts it to 3 phase output for the fan motor
- Fan speed is determined by the PSB circuit board which provides a 0-10vdc output to control the VFD

### CFW300/320 WEG Drive Read-Only Parameters (Brackets = CFW10)

Parameter	Function	Range	Unit	Description
P002	Motor Speed Output	0 to 66	Hz	Indicates the VFD Output Frequency in Hertz
P003	Motor Current Output	0 to 1.5 x I <sub>nom</sub>	A	Indicates the VFD Output Current in Amperes
P004	DC Link Voltage	0 to 524	V	Indicates the VFD DC Link Voltage in Volts
P007	Motor Voltage Output	0 to 240	V	Indicates the VFD Output Voltage in Volts
P030 (P008)	Module Temperature	25 to 110	°C	Indicates the VFD Temp in Celsius
P050 (P014)	Last Fault	00 to 41	FXXX (EXX)	Indicates the Code of the last occurred Fault (Error)
P060 (P015)	Second Fault Occurred	00 to 41	FXXX (EXX)	Indicates the Code of the 2nd last occurred Fault (Error)
P070 (P016)	Third Fault Occurred	00 to 41	FXXX (EXX)	Indicates the Code of the 3rd last occurred Fault (Error)

## WEG Drive Alarm/Fault Messages

When an alarm is detected, the drive continues to operate and an alarm code is displayed in the form AXXX to warn the user of critical operation conditions. When a fault is detected, the inverter is disabled and the fault code is displayed in the form FXXX (CFW10 = EXX).

See **Diagnostics & Troubleshooting (page 42)** for detailed descriptions of all alarm/fault messages.

## CFW300/320 WEG Drive Breakdown

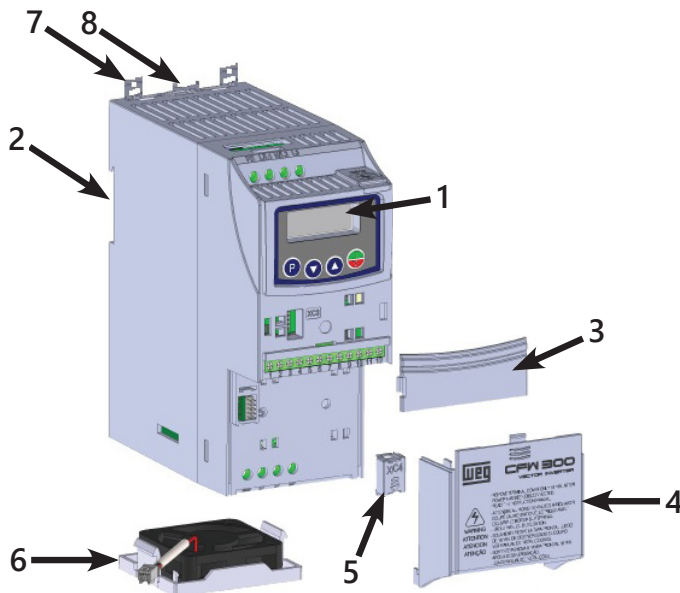

- 1 - HMI
- 2 - Mounting supports (for DIN rail mounting)
- 3 - Communication accessory cover
- 4 - Cover of the IO expansion accessory
- 5 - Protection cover of the connection of the IO expansion accessory
- 6 - Fan with mounting support
- 7 - Mounting feet (if DIN rail mounting isn't possible)
- 8 - DIN rail release button - to release drive from the DIN rail, depress the release button and pull

## System Commissioning & Set-up

### Determining Preliminary System Information

To set the air handler, the required airflow capacity must be determined for each operating mode. The required CFM/Ton is 250, 200, and 125 for Cooling, Heating and Recirculation Fan respectively. Divide the total CFM required for each fan speed by the total number of outlets. Keep in mind that each HE outlet represents two 2" outlets, and 2" outlets represent one. This will provide the average CFM per outlet. After all airflow capacities have been determined, convert the Airflow per outlet to Velocity per Outlet. This will make setting the air handler easier. Do this by dividing CFM per outlet by 0.022. This will provide FPM per 2" outlet. Divide CFM per outlet by 0.021 to provide FPM per HE outlet. Determining velocities per outlet for HE and 2" is important. The ideal outlet velocity that is calculated on page 2 & 3 of the commissioning report will be used when setting the airflow of the system. After the average outlet has been determined, the calculated ideal velocity per outlet will be what the average outlet should be set at.

### Fan Speed Adjustment

- Power Air Handler Unit
- Ensure all outlets are open
- Energize the thermostat setting to be adjusted. (Cooling, Heating or Recirculation Fan)
  - On the WEG drive press the Parameter button (P) until the parameter light (red) is illuminated
  - Using the arrow buttons scroll down to Parameter "000"
  - Press the Parameter button (P) again to enter the Parameter "000"
  - Change P000 to a value of "005". This unlocks the drive and allows you to change other parameters
  - Once parameter "000" is set to a value of "005" the drive is unlocked and the fan speeds can be adjusted via Parameters 124, 125, 126 and 127.

▶ 00.0 HZ is the minimum speed - 66.0HZ is the maximum speed

▶ Parameter 124 (P124) is to set the constant fan speed (G)

▶ Parameter 125 (P125) is to set the cooling speed (Y1 & Y2)

▶ Parameter 126 (P126) is to set the heating speed (W1 & W2)

▶ Parameter 127 (P127) is to set the Dehumidification speed (D)

- Fan speeds have been set in the factory for nominal CFM output. To ensure that supply airflow is sufficient for the specific application the speeds may need to be fine-tuned and confirmed via an airflow test. See the next section for details on the factory recommended method of setting airflow.

### Finding Average Outlet & Fine Tuning the Fan Speeds

With the preliminary adjustment set, fine tuning the fan speeds may commence. With the power on, all zone dampers opened, and the cooling speed energized, allow the fan 45 seconds to fully ramp up. Once the fan is fully ramped up, record velocity readings from all of the outlets (FPM or Knots). These outlet locations and velocity readings can be recorded on page 4 of the commissioning report. Ensure HE outlet velocities are recorded in section A (HE) of the chart and 2" outlet velocity are recorded in section B (2") of the chart. When all outlet velocity reading have been recorded, pick a section (A or B) with the most outlets. Total all velocities in that section, and divide that number by the number of outlets in the section selected. This provides a true average velocity of that selected section. Now that the average velocity of one section (HE or 2") has been determined, select one outlet in that section to make your average outlet. Now that we know what type of outlet our average is (HE or 2"), we can go back to the "Determining Preliminary System Information" section on pages 2 & 3 of the commissioning report and select the FPM per outlet that is specific to the type of average outlet we have.

Use the average outlet to fine tune the system by matching the average outlet's velocity (FPM per outlet) to the velocity per outlet that was determined for each fan speed.

For full and proper tuning of the fan speeds, repeat the above process for heating and recirculation fan. The same average outlet that was determined in cooling mode can be used again for tuning the other modes.

When tuning is complete, change WEG parameter back to P002, this displays hertz output to the motor.

### Important Notes:

- Initial adjustment of the fan speed for cooling, heating and recirculation fan must be done with all dampers in the open position, to verify maximum load capacities.

- To find outlet CFM:

Multiply Knots by 4.2 for HE and by 2.2 for 2"

Multiply FPM by 0.042 for HE and by 0.022 for 2"

## Options & Add-Ons

### Hot Water Coil Add-On (HWC)

Our Hydronic Water Coils are approved for use with potable water systems.

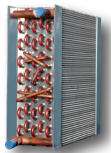

Designed for the Hi-Velocity System, the HWC is a High Capacity Hydronic Heating water coil that comes installed in the "H" Series air handlers and can be field installed in the "BU" Series air handlers. To install, simply remove the front blower panels, and slide the coil into place on the supply air side of the blower. (Fig. HWC-01)

The water coil is designed with 3/4" copper connections with 6 internal rows of 3/8" copper tubing, for high heat transfer ratings even when using low water temperature sources. The coil is factory tested at 500 psi for leaks, and is designed to have a low water pressure drop through the coil reducing pump head loss.

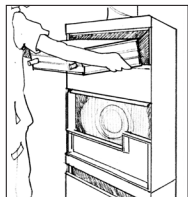

**Fig. HWC-01 - Hot Water Coil easily slides into the Air Handler**

The air handler can be installed in upflow, counterflow or horizontal positions, using the lowest water connection into the coil as the supply line and the highest water connection as the return line, to reduce possible air trapping within the coil. Typical hot water heating sources used are dual purpose hot water tanks (natural gas or oil), boilers (gas, oil, electric or wood fired), and even solar heating systems. Geo-thermal systems, water-to-water heat pumps or reverse cycle chillers would use the WM or WCM coils, as they have a drain pan incorporated within the coil casing, for condensate water formed from the cooling cycle.

When used with dual purpose hot water tanks, be sure to size the tank for both the domestic hot water usage as well as the heating requirements.

Table HWC-01 – WCM/WM Pipe Sizing

Zone BTUH Heat loss	Pipe Size up to 40 feet	Pipe Size 40 – 100 feet
0 - 35,000 (0 - 10.3 kW)	5/8" (16mm)	3/4" (19mm)
35,001 - 70,000 (10.4 - 20.5 kW)	3/4" (19mm)	1" (25mm)
70,001 - 140,000 (20.6 - 41.0 kW)	1" (25mm)	1 1/4" (32mm)

### Piping The Hot Water Coil

Size your supply and return lines according to Table HWC-01. Figs. HWC-02 and 03 illustrated typical pipe runs from a dual purpose hot water tank to a air handler. These drawings are only for reference as all piping has to be run according to local codes.

**Fig. HWC-02 - Hot Water Tank: With side take-offs**

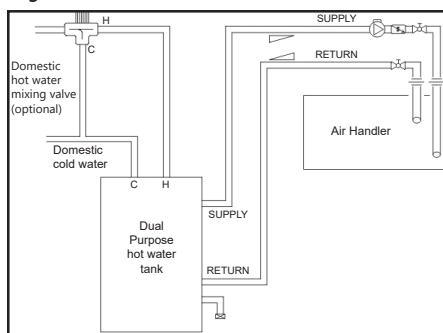

**Fig. HWC-03 - Hot Water Tank: Without side take-offs**

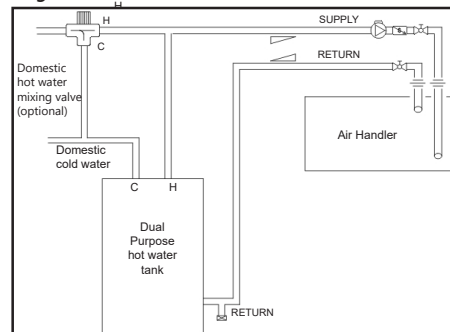

Incorporated within the circuit board there is a timer that when turned on will duty cycle the circulation pump for 5 minutes every 24 hours to ensure there is no stagnate water within the water coil. Spring check valves are required to be installed on the supply and return to prevent gravity flow from the hot water source on a call for cooling or constant fan.

Specifications	HWC-30 Coil	HWC-50 Coil	HWC-70 Coil	HWC-100 Coil	HWC-1750 Coil
Part Number	10050500030	20100100050	20100100070	20100100100	20100101750
Matching Air Handler	JH-15/30 CU-31	HE-Z/HE-B/HE-50/51 HV-50/51 CU-51, LV-Z/LV-B-750/751 LV-50	HE-Z/HE-B/HE-70/71 HV-70/71 LV-Z/LV-B-1050/1051 LV-70	HE-Z/HE-P-100/101 HE-B-100/101 HE/HV-100/101 LV-120/140	HE-P-240/241 LV-Z/LV-B-1750/1751
Max. BTUH 180°F E.W.T. (kW @ 82°C)	26,900 (7.9 kW)	54,500 (16.0 kW)	81,800 (24.0 kW)	122,900 (36.0 kW)	137,000 (40.0 kW)
Fin Material	Aluminum	Aluminum	Aluminum	Aluminum	Aluminum
Tubing Material	Copper	Copper	Copper	Copper	Copper
Type of Fins	.006 Al (0.1524mm)	.006 Al (0.1524mm)	.006 Al (0.1524mm)	.006 Al (0.1524mm)	.006 Al (0.1524mm)
GPM Flow Ratings (L/s Flow Ratings)	3 (0.18 L/s)	5 (0.32 L/s)	7 (0.44 L/s)	10 (0.63 L/s)	10 (0.63 L/s)
Hydronic Connection Sizes	Supply Line	3/8" (9mm)	3/4" (19mm)	3/4" (19mm)	1" (25mm)
	Return Line	3/8" (9mm)	3/4" (19mm)	3/4" (19mm)	1" (25mm)
Shipping Weight	5 lbs (2.3 kg)	17 lbs (7.7 kg)	22 lbs (10.0 kg)	29 lbs (13.2 kg)	45 lbs (20.4 kg)
Coil Dimensions (L x W x H)	13 1/2" x 3 1/3" x 12 1/2" (343mm x 85mm x 317mm)	13 1/2" x 5 1/2" x 16" (343mm x 140mm x 406mm)	19" x 5 1/2" x 16" (483mm x 140mm x 406mm)	25" x 5 1/2" x 16" (635mm x 140mm x 406mm)	26" x 6" x 22" (660mm x 152mm x 559mm)

BTUH - British Thermal Units per Hour  
EWT - Entering Water Temperature  
GPM - US Gallons per Minute  
L/s - Litres per Second

## Options & Add-Ons

### Refrigerant Base Modules (RBM)

SEE RBM MANUAL THAT COMES WITH COIL OR AT HI-VELOCITY.COM FOR COMPLETE INSTALLATION INFORMATION

The RBM Series Cooling Coil comes as a module and can be installed as a stand (return air base) for the air handler or as a side mounted coil. Modules come with thermal expansion valve (pre-installed), access port(s), external freeze stat and T-mounting brackets.



#### Airflow Configurations

##### Standard Coil

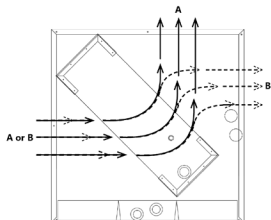

(Do not install in downflow configuration)

##### Adapted Coil

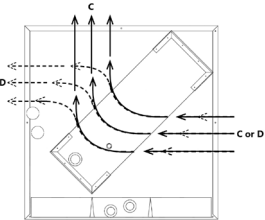

(Do not install in downflow configuration)

Specifications		RBM-50	RBM-70	RBM-100
Part Name/Number (A2L)		RBM-50-A2L P/N 41090304050	RBM-70-A2L P/N 41090304070	RBM-100-A2L P/N 41090304100
Part Name/Number (R410A)		RBM-50-R410A P/N 41090300050	RBM-70-R410A P/N 41090300070	RBM-100-R410A P/N 41090300100
Matching Air Handler		HE-Z/HE-B-50/51, CU-51 LV-Z/LV-B-750/751, LV-50	HE-Z/HE-B-70/71 LV-Z/LV-B-1050/1051 LV-70	HE-Z/HE-P/ HE-B-100/101 HE-P-240/241 (x2 Coils)
Tons <sup>(1)</sup>		1.5 - 2.0 (5.3 - 7.0 kW)	2.5 - 3.0 (8.8 - 10.6 kW)	3.5 - 5.0 (12.3 - 17.6 kW)
Refrigerant Type		R-410A	R-410A	R-410A
TX Cooling MBH <sup>(2)</sup>		18-24 (5.3-7.0 kW)	30-36 (8.8-10.6 kW)	42-60 (12.3-17.6 kW)
Latent Cooling MBH		6.8-8.9 (2.0-2.6 kW)	11.7-13.7 (3.4-4.0 kW)	16.0-22.2 (4.7-6.5 kW)
Hydronic Connection Sizes	Liquid (Lq)	3/8" (9.5mm)	3/8" (9.5mm)	3/8" (9.5mm)
	Suction (S)	7/8" (22.3mm)	7/8" (22.3mm)	7/8" (22.3mm)
	Drain	3/4" M CPVC (19mm)	3/4" M CPVC (19mm)	3/4" M CPVC (19mm)
TXV with Built-in Check Valve & Bypass		Pre-Installed	Pre-Installed	Pre-Installed
Freeze Stat		Yes	Yes	Yes
Access Ports		Yes	Yes	Yes
Shipping Weight		35 lbs (15.9 kg)	45 lbs (20.4 kg)	55 lbs (24.9 kg)
Module Size (L x W x H)		14 1/2" x 18 1/4" x 18 1/4" (368mm x 464mm x 464mm)	19 1/2" x 18 1/4" x 18 1/4" (495mm x 464mm x 464mm)	25 1/2" x 18 1/4" x 18 1/4" (648mm x 464mm x 464mm)

(1) Minimum of **four HE outlets per ton** of cooling needed. (2<sup>o</sup>) Duct = Minimum **eight 2" outlets per ton**

MBH - Thousand British Thermal Units per Hour  
TX - Thermal Expansion  
TXV - Thermal Expansion Valve

### Refrigerant Modules (RCM)

SEE RCM MANUAL THAT COMES WITH COIL OR AT HI-VELOCITY.COM FOR COMPLETE INSTALLATION INFORMATION

The RCM Series Cooling Coil comes as a module and must be installed in the vertical position on the return air side of the air handler. This module comes with thermal expansion valve, access port(s), external freeze stat and two L mounting brackets.

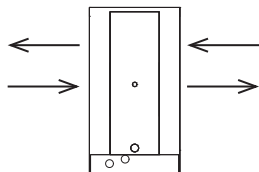

#### Airflow

Specifications		RCM-30	RCM-50	RCM-70	RCM-100
Part Name/Number (A2L)		RCM-30-A2L P/N 10090204050	RCM-50-A2L P/N 10090204050	RCM-70-A2L P/N 0090204070	RCM-100-A2L P/N 40090204100
Part Name/Number (R410A)		RCM-30-R410A P/N 4090200030	RCM-50-R410A P/N 10090200050	RCM-70-R410A P/N 10090200070	RCM-100-R410A P/N 40090200100
Matching Air Handler		CU-31 JH-15/30	HE-Z/HE-B-50/51, CU-51 LV-Z/LV-B-750/751, LV-50	HE-Z/HE-B-70/71 LV-Z/LV-B-1050/1051 LV-70	HE-Z/HE-P/ HE-B-100/101 HE-P-240/241 (x2 Coils)
Tons <sup>(1)</sup>		1.0 Ton (3.5 kWh)	1.5 - 2.0 (5.3 - 7.0 Kw)	2.5 - 3.0 (8.8 - 10.6 Kw)	3.5 - 5.0 (12.3 - 17.6 Kw)
Refrigerant Type		R-410A	R-410A	R-410A	R-410A
TX Cooling MBH <sup>(2)</sup>		6-12 (1.8-3.5 kW)	18-24 (5.3-7.0 kW)	30-36 (8.8-10.6 kW)	42-60 (12.3-17.6 kW)
Hydronic Connection Sizes	Liquid (Lq)	3/8" (9.5mm)	1/2" (13mm)	1/2" (13mm)	1/2" (13mm)
	Suction (S)	5/8" (15.9mm)	7/8" (22.3mm)	7/8" (22.3mm)	7/8" (22.3mm)
	Drain	3/4" M CPVC (19mm)	3/4" M CPVC (19mm)	3/4" M CPVC (19mm)	3/4" M CPVC (19mm)
TXV with Built-in Check Valve & Bypass		Yes	Yes	Yes	Yes
Freeze Stat		Yes	Yes	Yes	Yes
Access Port(s)		Yes	Yes	Yes	Yes
Shipping Weight		17 lbs (7.7 kg)	27 lbs (12.2 kg)	34 lbs (15.4 kg)	45 lbs (20.4 kg)
Module Size (L x W x H)		14 3/8" x 12 1/4" x 12 3/8" (365mm x 311mm x 314mm)	14 3/8" x 10 1/8" x 18 1/2" (365mm x 257mm x 470mm)	19 3/8" x 10 1/8" x 18 1/2" (492mm x 257mm x 470mm)	25 3/8" x 10 1/8" x 18 1/2" (645mm x 257mm x 470mm)

(1) Minimum of **four HE outlets per ton** of cooling needed. (2<sup>o</sup>) Duct = Minimum **eight 2" outlets per ton**

MBH - Thousand British Thermal Units per Hour  
TX - Thermal Expansion  
TXV - Thermal Expansion Valve

## Options & Add-Ons

### Chilled Water Base Module (WBM)

**SEE WBM MANUAL THAT COMES WITH THE COIL OR AT HI-VELOCITY.COM FOR COMPLETE INSTALLATION INFORMATION**

The WBM coil is a High Capacity Hydronic Water Coil available as an add-on module to the Hi-Velocity System. The WBM module can be installed as a stand (return air base) for the air handler or as a side mounted coil. Mainly used in chilled water applications for cooling, this coil can also be used for heating with water temperatures up to 130°F (54°C).



#### Airflow Configurations

##### Standard Coil

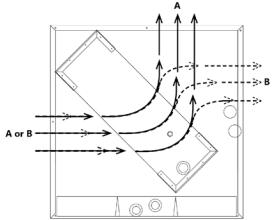

(Do not install in downflow configuration)

##### Adapted Coil

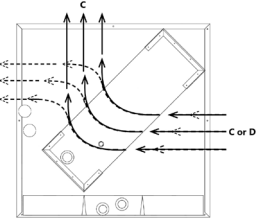

(Do not install in downflow configuration)

Specifications		WBM-50	WBM-70	WBM-100
Matching Air Handler		HE-Z/HE-B-50/51 CU-51 LV-50	HE-Z/HE-B-70/71 LV-70 LV-Z-1050	HE-Z/HE-P/HE-B-100/101 LV-120/140 LV-Z-1050
Part Number		40090400050	40090400070	40090400100
BTUH 80°/67° @ 42°F E.W.T. (27°/19 @ 5.5°C E.W.T.)		18,000-24,000 (5.3-7.0 kW)	30,000-36,000 (8.8-10.6 kW)	42,000-60,000 (12.3-17.6 kW)
Fin Material		Aluminum	Aluminum	Aluminum
Tubing Material		Copper	Copper	Copper
Type of Fins		.006 Al (0.1524mm)	.006 Al (0.1524mm)	.006 Al (0.1524mm)
GPM Flow Ratings		5 (0.32 L/s)	7 (0.44 L/s)	10 (0.63 L/s)
Hydronic Connection Sizes	Supply Line	3/4" (19mm)	3/4" (19mm)	3/4" (19mm)
	Return Line	3/4" (19mm)	3/4" (19mm)	3/4" (19mm)
	Drain	3/4" M CPVC (19mm)	3/4" M CPVC (19mm)	3/4" M CPVC (19mm)
Shipping Weight		35 lbs (15.9 kg)	45 lbs (20.4 kg)	55 lbs (25.0 kg)
Module Size (L x W x H)		14 1/2" x 18 1/4" x 18 1/4" (368mm x 464mm x 464mm)	19 1/2" x 18 1/4" x 18 1/4" (495mm x 464mm x 464mm)	25 1/2" x 18 1/4" x 18 1/4" (648mm x 464mm x 464mm)

BTUH - British Thermal Units per Hour  
EWT - Entering Water Temperature  
GPM - US Gallons per Minute  
L/s - Litres per Second

Our Hydronic Water Coils are approved for use with potable water systems.

### Chilled Water Coil Module (WCM/WM)

**SEE WCM MANUAL THAT COMES WITH COIL OR AT HI-VELOCITY.COM FOR COMPLETE INSTALLATION INFORMATION**

The WCM/WM coil is a High Capacity Chilled Water Coil available as an add-on module to the Hi-Velocity System. Mainly used in the chilled water applications for cooling, this coil can also be used for heating with water temperatures up to 130°F (54°C). The coil comes as a module and must be installed in the vertical position on the return air side of the air handler. The WCM/WM come supplied with two L mounting brackets for connection to the air handler.

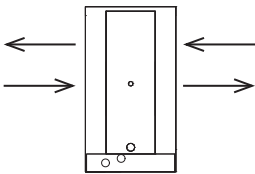

#### Airflow

Specifications	WCM-50	WCM-70/1050	WCM-100	WM-1750
Part Number	10010201050	10010201070	40090100100	20090101750
Matching Air Handler	HE-Z/HE-B-50/51 CU-51 LV-Z/LV-B-750/751 LV-50	HE-Z/HE-B-70/71 LV-Z/LV-B-1050/1051 LV-70	HE-Z/HE-B-100/101 LV-Z/LV-B-1050/1051 LV-120/140	HE-P-240/241 LV-Z/LV-B-1750/1751
BTUH 80°/67° @ 42°F E.W.T. (27°/19 @ 5.5°C E.W.T.)	18,000-24,000 (5.3-7.0 kW)	30,000-36,000 (8.8-10.6 kW)	42,000-60,000 (12.3-17.6 kW)	42,000-70,000 (12.3-20.5 kW)
Fin Material	Aluminum	Aluminum	Aluminum	Aluminum
Tubing Material	Copper	Copper	Copper	Copper
Type of Fins	.006 Al (0.1524mm)	.006 Al (0.1524mm)	.006 Al (0.1524mm)	.006 Al (0.1524mm)
GPM Flow Ratings	5 (0.32 L/s)	7 (0.44 L/s)	10 (0.63 L/s)	10 (0.63 L/s)
Hydronic Connection Sizes	Supply Line	3/4" (19mm)	3/4" (19mm)	1" (25mm)
	Return Line	3/4" (19mm)	3/4" (19mm)	1" (25mm)
	Drain	3/4" M CPVC (19mm)	3/4" M CPVC (19mm)	3/4" M CPVC (19mm)
Shipping Weight		26 lbs (11.8 kg)	33 lbs (15.0 kg)	44 lbs (20.0 kg)
Module Size (L x W x H)		14 3/8" x 10 1/8" x 18 1/2" (365mm x 257mm x 470mm)	19 3/8" x 10 1/8" x 18 1/2" (492mm x 257mm x 470mm)	25 3/8" x 10 1/8" x 18 1/2" (645mm x 257mm x 470mm)
				26 1/4" x 8 1/4" x 22 5/8" (656mm x 209mm x 575mm)

BTUH - British Thermal Units per Hour  
EWT - Entering Water Temperature  
GPM - US Gallons per Minute  
L/s - Litres per Second

## Options & Add-Ons

### Variable Electrical Strip Heater (VESH)

SEE VESH MANUAL THAT COMES WITH THE COIL OR AT HI-VELOCITY.COM FOR COMPLETE INSTALLATION INFORMATION

The Variable Electrical Strip Heater (VESH) is an Advance Power Savings electric resistance heater which modulates the output based on the selection setting of the supply air duct sensor and the system leaving air temperature. The VESH slides into the air handler on the leaving air side (supply side) of the blower. This heater can be used for primary heating or supplemental (auxiliary) heating for heat pumps.



Specifications	VESH - 400	VESH - 650	VESH - 750	VESH - 1100	VESH - 2500
Part Number	5 kW - 10025404005	10 kW - 10025654010	10 kW - 10025754010	10 kW - 10025114010	10 kW - 10025254010
		15 kW - 10025654015	18 kW - 10025754018	18 kW - 10025114018	15 kW - 10025254015
				23 kW - 10025114023	20 kW - 10025254020
					25 kW - 10025254025
Matching Air Handler	CU-31 BU	HE-Z/HE-B-50/51 BU CU-51 BU LV-Z/LV-B-750/751 BU LV-50 BU	HE-Z/HE-B-70/71 BU LV-Z/LV-B-1050/1051 BU LV-70 BU	HE-Z/HE-B-100/101 BU LV-120/140 BU	HE-P-240 BU LV-Z-1750 BU
Volts	240	240	240	240	240
Phase	1	1	1	1	1
Shipping Weight	20 lbs (9.1 kg)	21 lbs (9.5 kg)	27 lbs (12.2 kg)	28 lbs (12.7 kg)	30 lbs (13.6 kg)
Coil Dimensions <sup>(1)</sup> (L x W x H)	13 3/4" x 5 5/8" x 12 1/8" (349mm x 143mm x 308mm)	13 3/4" x 5 5/8" x 17" (349mm x 143mm x 432mm)	18 3/4" x 5 5/8" x 17" (476mm x 143mm x 432mm)	24 3/4" x 5 5/8" x 17" (629mm x 143mm x 432mm)	25 3/4" x 6" x 21 7/8" (654mm x 152mm x 556mm)

<sup>(1)</sup> Dimensions for VESH do not include the electrical access panel, add 4" to L for total length (add 5" for VESH-2500)

### Electrical Strip Heater (ESH)

SEE ESH MANUAL THAT COMES WITH THE COIL OR ON HI-VELOCITY.COM FOR COMPLETE INSTALLATION INFORMATION

The Electrical Strip Heater (ESH) is an electric resistance heater that slides into the air handler on the leaving air side (supply side) of the blower. This heater can be used for primary heating or supplemental heat (auxiliary heating) for heat pumps.



Specifications	ESH - 650	ESH - 750	ESH - 1100	ESH-2500
Part Number	5 kW - 10025650005	5 kW - 10025750005	10 kW - 10025110010	10 kW - 10025250010
	10 kW - 10025650010	10 kW - 10025750010	15 kW - 10025110015	15 kW - 10025250015
	15 kW - 10025650015	15 kW - 10025750015	18 kW - 10025110018	20 kW - 10025250020
		18 kW - 10025750018	20 kW - 10025110020	25 kW - 10025250025
			23 kW - 10025110023	
Matching Air Handler	HE-Z/HE-B/HE/ HV-50/51 BU, CU-51 BU, LV-Z/LV-B-750/751 BU, LV-50 BU	HE-Z/HE-B/HE/ HV-70/71 BU LV-Z/LV-B-1050/1051 BU LV-70 BU	HE-Z/HE-B/HE/ HV-100/101 BU LV-120/140 BU	HE-P-240 BU, LV-Z-1750 BU
Volts	240	240	240	240
Phase	1	1	1	1
Shipping Weight	21 lbs (9.5 kg)	27 lbs (12.2 kg)	28 lbs (12.7 kg)	30 lbs (13.6 kg)
Coil Dimensions <sup>(1)</sup> (L x W x H)	13 3/4" x 5 5/8" x 17" (349mm x 143mm x 432mm)	18 3/4" x 5 5/8" x 17" (476mm x 143mm x 432mm)	24 3/4" x 5 5/8" x 17" (629mm x 143mm x 432mm)	25 3/4" x 6" x 21 7/8" (654mm x 152mm x 556mm)

<sup>(1)</sup> Dimensions for ESH do not include the electrical access panel, add 4" to L for total length

## Options & Add-Ons

### Hi-Velocity Air Purification System



Easily installed on any Hi-Velocity or existing HVAC System, the optional HEPS gives consumers unsurpassed indoor air quality. Three powerful technologies in one Air Purification System:

- Electrostatic MERV-13 Filter Removes Allergens
- Photo-Catalytic Oxidation destroys toxic chemicals and eliminates household odors
- Ultraviolet Light Neutralizes Disease Germs on Contact

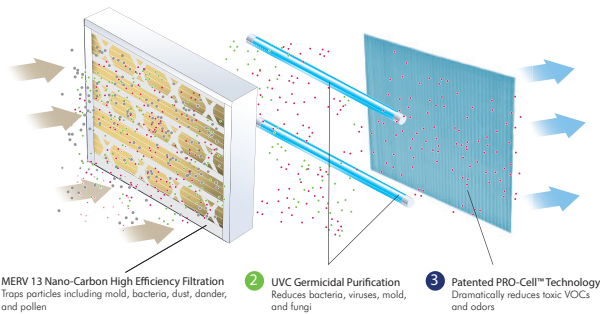

### Filter Rack

Also available from Energy Saving Products is a FR Filter Rack (1") and a FR-4 Filter Rack (4"). The FR 1" filter is a MERV 3 which is 14% efficient and the FR-4 is a 4" MERV 13 which is 85% efficient. Aftermarket filters may be used with the Hi-Velocity filter racks. (See filter dimensions below)

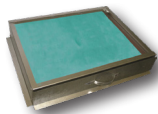

1" Filter Rack and Filter



4" Filter Rack and Filter

### Filter Dimensions

Unit	50/51	70/71	100/101	240/1750
FR Filter	14" x 18" x 1"	18" x 18" x 1"	24" x 18" x 1"	24" x 26" x 1"
FR-4 Filter	14" x 18" x 4"	19" x 18" x 4"	25" x 18" x 4"	-

### Hi-Velocity Portable Air Purification System



Our P-20 Portable Hi-Velocity Air Purification System is a powerfully advanced stand-alone system that has 5 steps to give you the cleanest air possible:

- Step 1: A Treated Pre-filter removes all particles from the air larger than 5 microns.
- Step 2: A hospital grade HEPA Filter removes allergens so small they can only be seen by a microscope.
- Step 3: A specially formulated Gas Absorption Media removes toxic fumes.
- Step 4: "Photo-Catalytic Oxidation" destroys toxic chemicals and eliminates household odors.
- Step 5: Ultraviolet light 10,000 times the intensity of sunlight neutralizes viruses and bacteria on contact.

Electronic sensors monitor air quality and automatically increase air purifier performance to compensate for periods of usually high chemical activity or during periods of high particle counts.

### Turbo Meter™ from Davis Instruments



The Turbo Meter provides uncommon accuracy, sensitivity, and pocket-sized convenience. It is based on the principle that a freely turning turbine will rotate at a speed directly proportional to the wind speed. To insure maximum sensitivity and accuracy, the turbine is suspended on sapphire jewel bearings, and its rotation is sensed by an infrared light beam which adds no friction. The resulting signal is processed electronically by an LSI (Large Scale Integrated) circuit for improved reliability and reduced size. A special three digit display is used for extra resolution and provides excellent viewing contrast in bright sunlight. A handy switch selects between four different scales — knots, feet per minute, meters per second, and miles per hour — for unmatched versatility. Unit is compact size (2.6 x 4.7", 7x 12cm) and light weight ( 3oz., 85g). Measures wind speed from 0 - 99.9 mph. Available from Energy Saving Products, or directly from Davis Instruments.

### Third Party Options

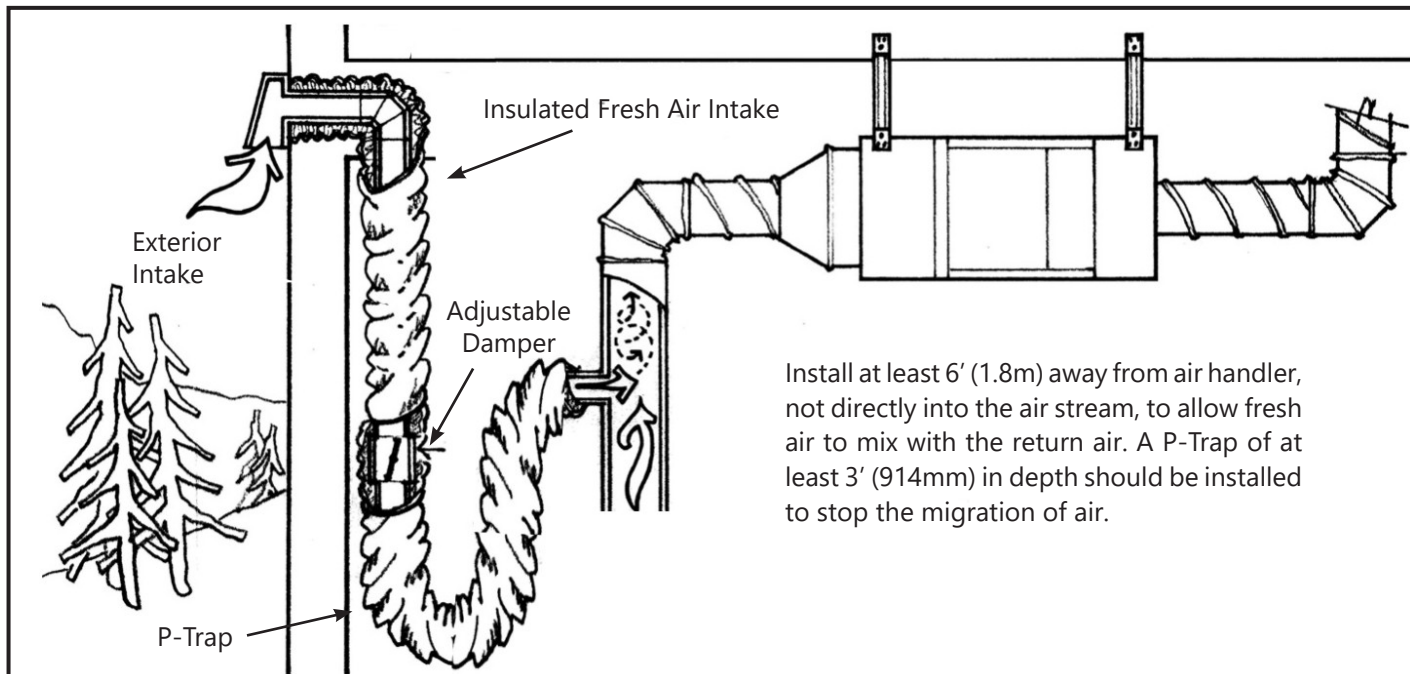

Install at least 6' (1.8m) away from air handler, not directly into the air stream, to allow fresh air to mix with the return air. A P-Trap of at least 3' (914mm) in depth should be installed to stop the migration of air.

#### Fresh Air Make-Up

For areas that require fresh air make-up, a small intake may have to be installed. It is recommended to install an insulated flex duct, with a damper, into the return air plenum. The damper can then be adjusted to supply the exact amount of fresh air needed to meet local building codes (Fig. OPT-03). This should be balanced to the exhaust air levels of the structure. Either filter the combined air stream through a common filter or use separate filters for both air streams.

Install the fresh air duct to the side of the return air and not directly into the air stream. As shown in Fig. 03, the fresh air duct should be installed more than 6' (1.8m) away from the air handler and before a 90° bend.

If too large of a duct is installed, the excess fresh air will increase system operating costs and decrease system performance.

An approximate fresh air duct sizing is: 3" (76mm) for the 50 unit, 4" (102mm) for the 70 unit, and 5" (127mm) for the 100 unit.

#### Fire Stopping

Some areas require a Fire Stopping device to stop the spread of a fire and/or prevent the duct system from supplying oxygen to the fire. The Hi-Velocity System can be used in conjunction with several types of Fire Stopping devices such as pipe collars, wrap strips and mechanical shut-offs.

With our Rough-In Boots, Metacaulk pipe collars work very well; Fig. OPT-04 gives an illustration of a pipe collar used with the Rough-In Boot. Many options are available to the designer. If assistance is needed in product choice, call our representatives at Energy Saving Products for free technical advice.

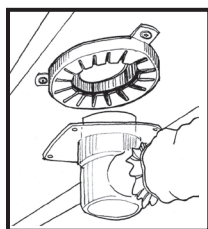

Fig. OPT-04  
Fire Stopping Devices

#### Humidity Control

It is recommended to use a steam humidifier in single zone applications. For multi-zone applications, contact the manufacturer.

When a bypass type humidifier is used, the humidifier can be mounted on the return air duct, and then a 2" (51mm) take-off from the hot air side is run back (Fig. OPT-05). DO NOT use any size larger than 2" (51mm), and be sure to install a summer shut-off, or it will create problems with the airflow.

Fig. OPT-05 – Humidifier

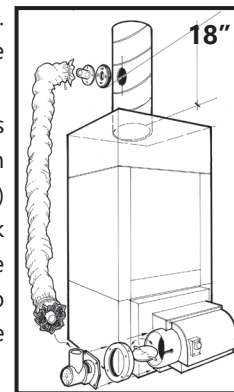

#### HRV/ERV

An HRV (Heat Recovery Ventilator) is typically a flat-plate air-to-air heat exchanger that transfers temperature between the two air streams. An ERV (Energy Recovery Ventilator) will exchange water vapour as well as temperature. It is usually a "heat wheel" and some amount of air will leak between the two airstreams. It is generally more costly than an HRV but it has the advantage of reducing the latent capacity and not just the sensible capacity.

There are several ways to integrate these products into the Hi-Velocity System. The easiest is to draw the exhaust from the return duct and then to add the fresh air a minimum of 5' downstream.

However, the best method is to have a separate return for the exhaust air. This will minimize any short circuiting of air between the fresh air and the exhaust, optimizing the location of the exhaust returns, which are best located in bathrooms.

## Diagnostics and Troubleshooting

### CFW300/320 WEG Alarms/Faults and Possible Causes (Brackets = CFW10)

This section assists the user to identify and correct possible alarms/faults that can occur during the WEG operation. When an alarm is detected, the drive continues to operate and an alarm code is displayed in the form AXXX to warn the user of critical operation conditions. When a fault is detected, the inverter is disabled and the fault code is displayed in the form FXXX (CFW10 = EXX). To restart the inverter after an alarm/fault has occurred, the drive must be reset.

#### To reset WEG drive: Disconnect and reapply the AC power (power-on reset)

ALARM CODE	DESCRIPTION	POSSIBLE CAUSES
<b>A046</b> Motor Overload	Motor overload alarm	<ul style="list-style-type: none"> <li>▶ Settings of P156 is too low for the used motor</li> <li>▶ Overload on the motor shaft</li> </ul>
<b>A050</b> Power Module/IGBT Overtemperature	Overtemperature alarm from the power module temperature sensor [NTC]	<ul style="list-style-type: none"> <li>▶ High temperature at IGBTs: P030 &gt; 90 °C [&gt; 194 °F]</li> <li>▶ High ambient temperature around the inverter &gt; 50 °C [&gt; 122 °F] and high output current</li> <li>▶ Blocked or defective fan</li> <li>▶ Heatsink is too dirty, preventing the air flow</li> </ul>
<b>A090</b> External Alarm	External alarm via Dlx [option "no external alarm" in P263 to P270]	<ul style="list-style-type: none"> <li>▶ Wiring on DI1 to DI8 inputs are open or have poor contact</li> </ul>
<b>A700</b> Remote HMI Communication	No communication with remote HMI, but there is frequency command or reference for this source	<ul style="list-style-type: none"> <li>▶ Check if the communication interface with the HMI is properly configured in parameter P312</li> <li>▶ HMI cable disconnected</li> </ul>

FAULT CODE	DESCRIPTION	POSSIBLE CAUSES
<b>F021 (E02)</b> Undervoltage on the DC Link	Undervoltage fault on the intermediate circuit	<ul style="list-style-type: none"> <li>▶ Wrong voltage supply; check if the data on the inverter label comply with the power supply and parameter P296</li> <li>▶ Supply voltage too low, producing voltage on the DC link below the minimum value - P004 Ud &lt; 250 Vdc in 110 / 127 Vac - P296 = 1, or Ud &lt; 200 Vdc in 200 / 240 Vac - P296 = 2</li> <li>▶ Phase fault in the input</li> <li>▶ Fault in the pre-charge circuit</li> </ul>
<b>F022 (E01)</b> Overvoltage on the DC Link	Overvoltage fault on the intermediate circuit	<ul style="list-style-type: none"> <li>▶ Wrong voltage supply; check if the data on the inverter label comply with the power supply and parameter P296</li> <li>▶ Supply voltage is too high, producing voltage on the DC link above the maximum value - P004 Ud &gt; 460 Vdc in 110 / 127 Vac - P296 = 1, or Ud &gt; 410 Vdc in 200 / 240 Vac - P296 = 2</li> <li>▶ Load inertia is too high or deceleration ramp is too fast</li> <li>▶ P151 setting is too high</li> </ul>
<b>F031</b> Fault in Communication with IOs Expansion Accessory	Main control cannot establish the communication link with the IOs expansion accessory	<ul style="list-style-type: none"> <li>▶ Accessory damaged</li> <li>▶ Poor connection of the accessory</li> <li>▶ Problem in the identification of the accessory; refer to P027</li> </ul>
<b>F032</b> Fault in Communication with IOs Communication Accessory	Main control cannot establish the communication link with the communication accessory	<ul style="list-style-type: none"> <li>▶ Accessory damaged</li> <li>▶ Poor connection of the accessory</li> <li>▶ Problem in the identification of the accessory; refer to P028</li> </ul>
<b>F051 (E04)</b> IGBTs Overtemperatures	Overtemperature fault measured on the temperature sensor of the power pack	<ul style="list-style-type: none"> <li>▶ High temperature at IGBTs: P030 (P008) &gt; 100 °C [&gt; 212 °F]</li> <li>▶ High ambient temperature around the inverter &gt; 50 °C [&gt; 122 °F] and high output current</li> <li>▶ Blocked or defective fan</li> <li>▶ Heatsink is too dirty, preventing the air flow</li> </ul>
<b>F070 (E00)</b> Overcurrent/Short-circuit	Overcurrent or short-circuit on the output, DC link or braking resistor	<ul style="list-style-type: none"> <li>▶ Short-circuit between two motor phases</li> <li>▶ IGBTs module in short-circuit or damaged</li> <li>▶ Start with too short acceleration ramp</li> <li>▶ Start with motor spinning without the Flying Start function</li> </ul>
<b>F072 (E05)</b> Motor Overload	Motor overload fault [60 s in 1.5 x I <sub>nom</sub> ]	<ul style="list-style-type: none"> <li>▶ P156 setting is too low in relation to the motor operating current</li> <li>▶ Overload on the motor shaft</li> </ul>
<b>F080 (E08)</b> CPU Fault (Watchdog)	Fault related to the supervision algorithm of the inverter main CPU	<ul style="list-style-type: none"> <li>▶ Electric noise</li> <li>▶ Inverter firmware fault</li> </ul>
<b>F081</b> End of User's Memory	Fault of end of memory to save user's parameter table	<ul style="list-style-type: none"> <li>▶ Attempt to save [P204 = 9] more than 32 parameters [with values different from the factory default] on the User parameter table</li> </ul>
<b>F082</b> Fault in the Copy Function (MMF)	Fault in the copy of parameters	<ul style="list-style-type: none"> <li>▶ Attempt to copy the parameters from the flash memory module to the inverter with different software versions</li> </ul>
<b>F084</b> Auto-diagnosis Fault	Fault related to the automatic identification algorithm of the inverter hardware	<ul style="list-style-type: none"> <li>▶ Poor contact in the connection between the main control and the power pack</li> <li>▶ Hardware not compatible with the firmware version</li> <li>▶ Defect on the internal circuits of the inverter</li> </ul>
<b>F091 (E06)</b> External Fault	External fault via Dlx ["no external fault" in P263 to P270]	<ul style="list-style-type: none"> <li>▶ Wiring on DI1 to DI8 inputs are open or have poor contact</li> </ul>
<b>F701</b> Remote HMI Communication Fault	No communication with the remote HMI; however, there is command or frequency reference for this source	<ul style="list-style-type: none"> <li>▶ Check that the HMI communication interface is properly configured in parameter P312</li> <li>▶ HMI cable disconnected</li> </ul>
<b>(E09)</b> Program Memory Error (Checksum)	Contact Energy Saving Products 1-888-652-2219	<ul style="list-style-type: none"> <li>▶ Memory with corrupted values.</li> </ul>
<b>(E24)</b> Programming error	It is automatically reset when the incompatible parameters are changed	<ul style="list-style-type: none"> <li>▶ Incompatible parameters were programmed.</li> </ul>
<b>(E31)</b> Keypad (HMI) Connection Fault	Contact Energy Saving Products 1-888-652-2219	<ul style="list-style-type: none"> <li>▶ Inverter control circuit is defective.</li> <li>▶ Electrical noise in the installation (electromagnetic interference).</li> </ul>
<b>(E41)</b> Self-Diagnosis Fault	Contact Energy Saving Products 1-888-652-2219	<ul style="list-style-type: none"> <li>▶ Inverter power circuit is defective.</li> </ul>

## Troubleshooting - Motor Running Too Fast

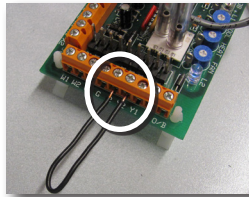
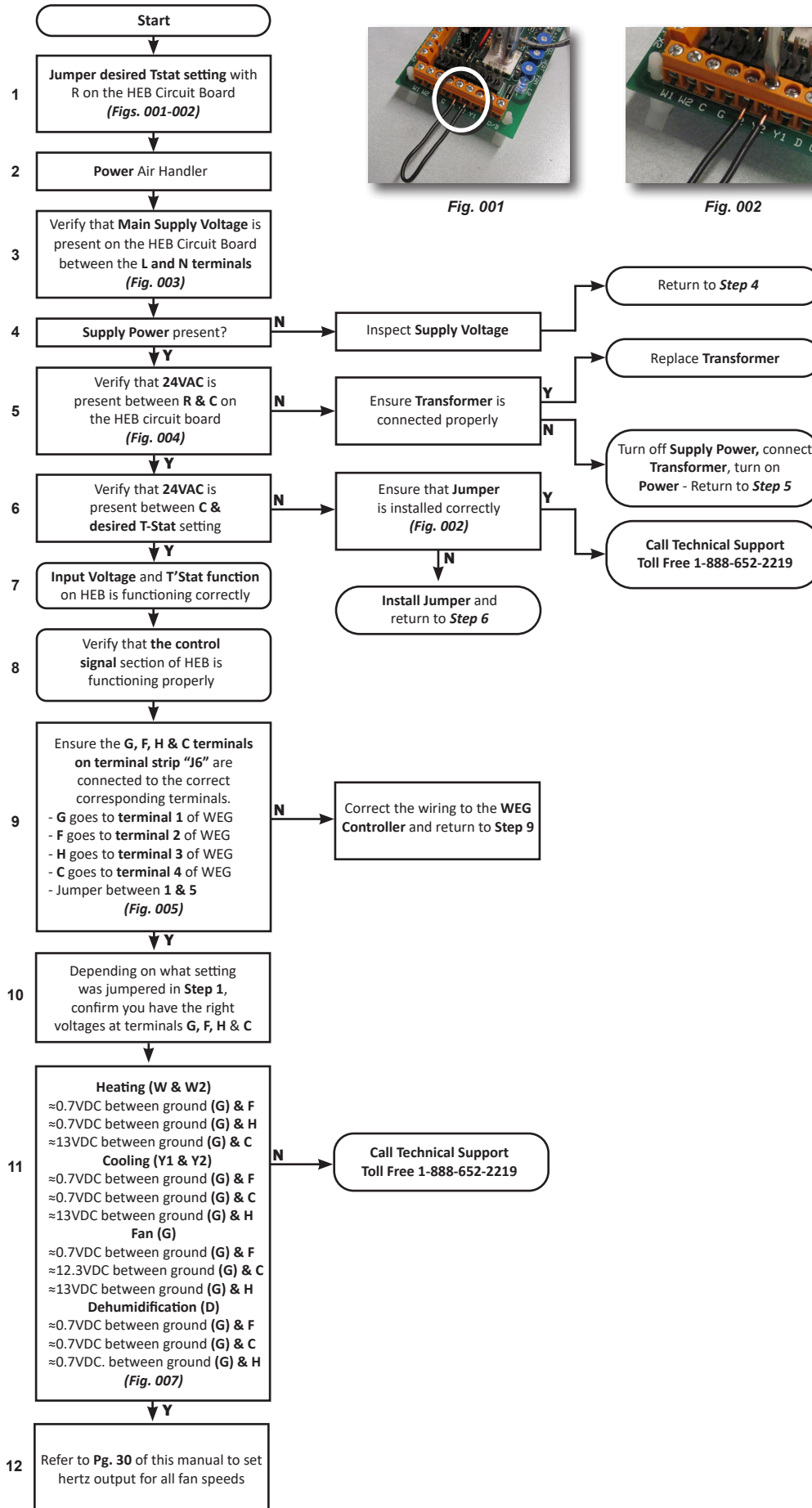

Fig. 001

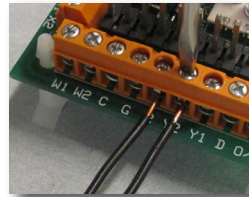

Fig. 002

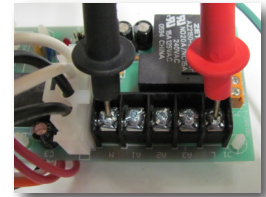

Fig. 003

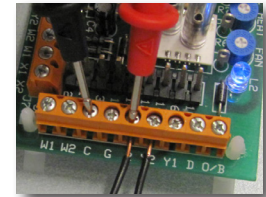

Fig. 004

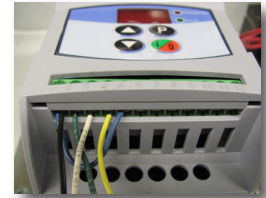

Fig. 005

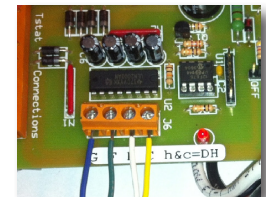

Fig. 006

## Troubleshooting - Motor Running Too Slow/Not Running

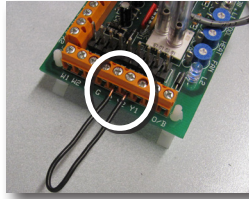
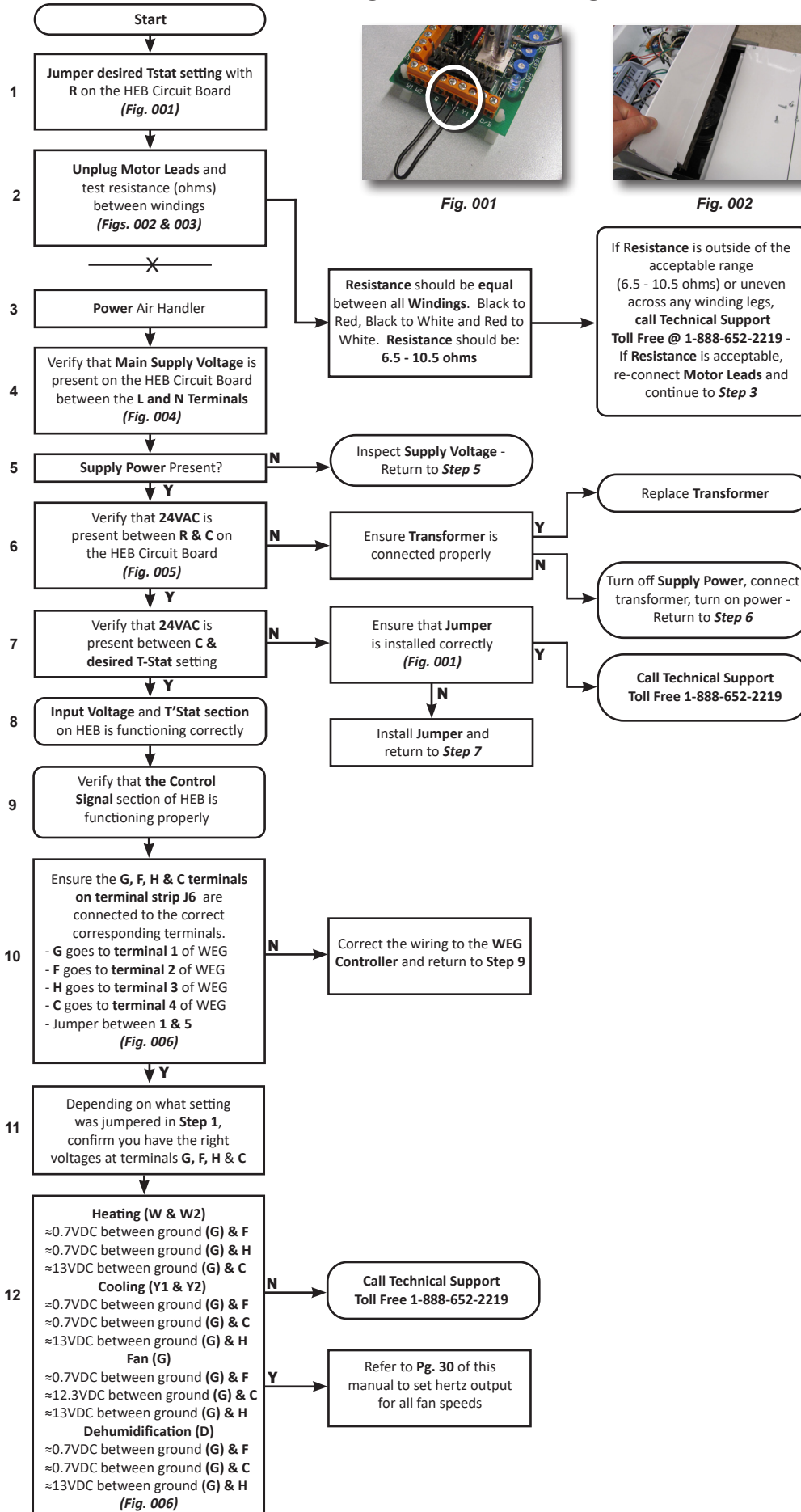

Fig. 001



Fig. 002



Fig. 003

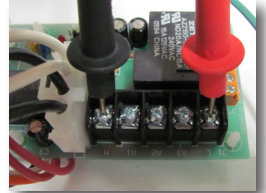

Fig. 004

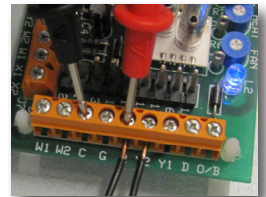

Fig. 005

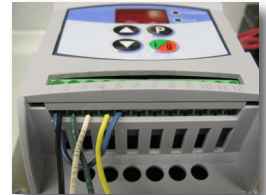

Fig. 006

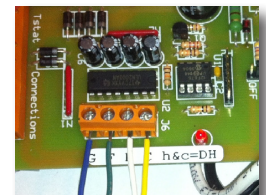
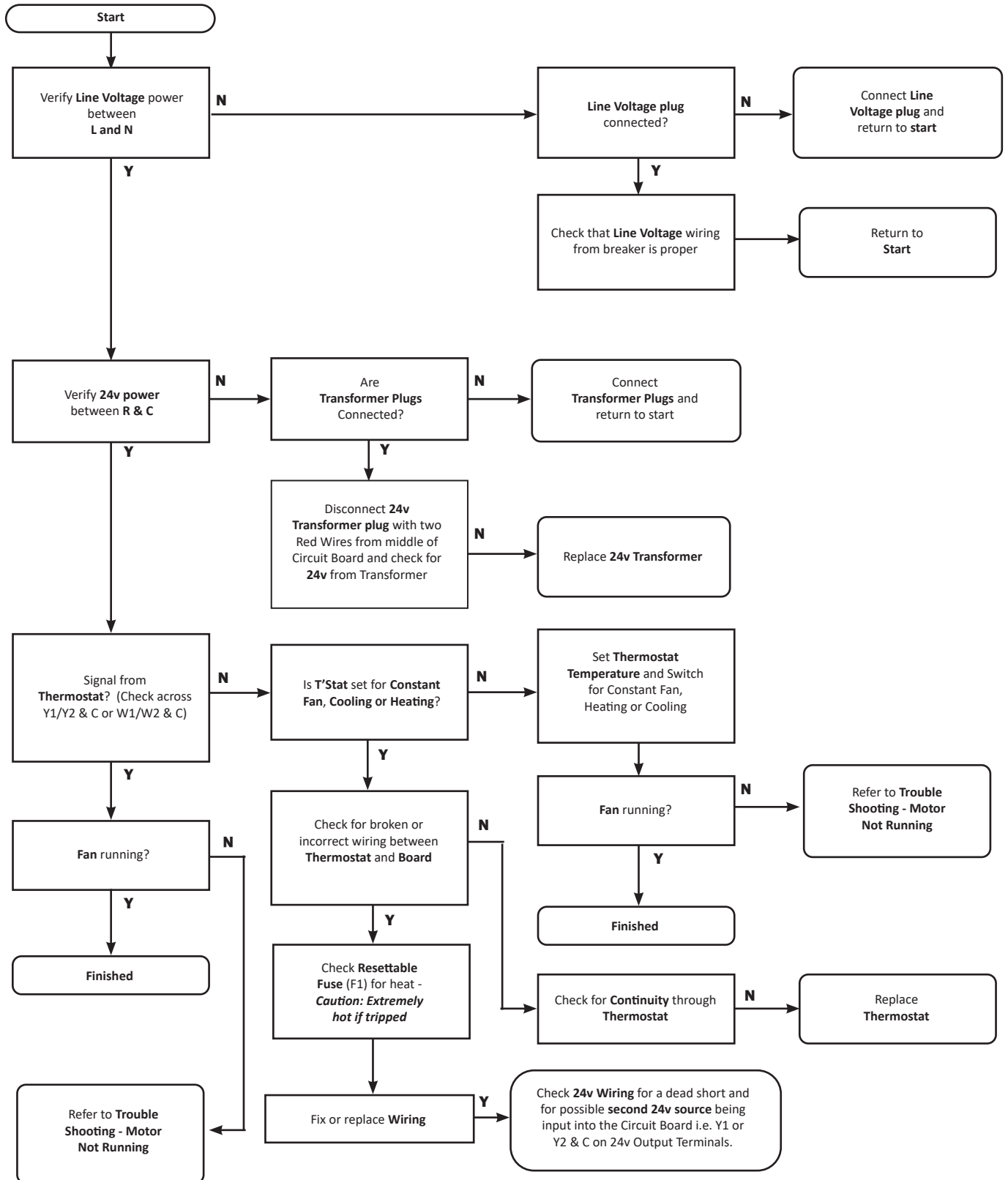
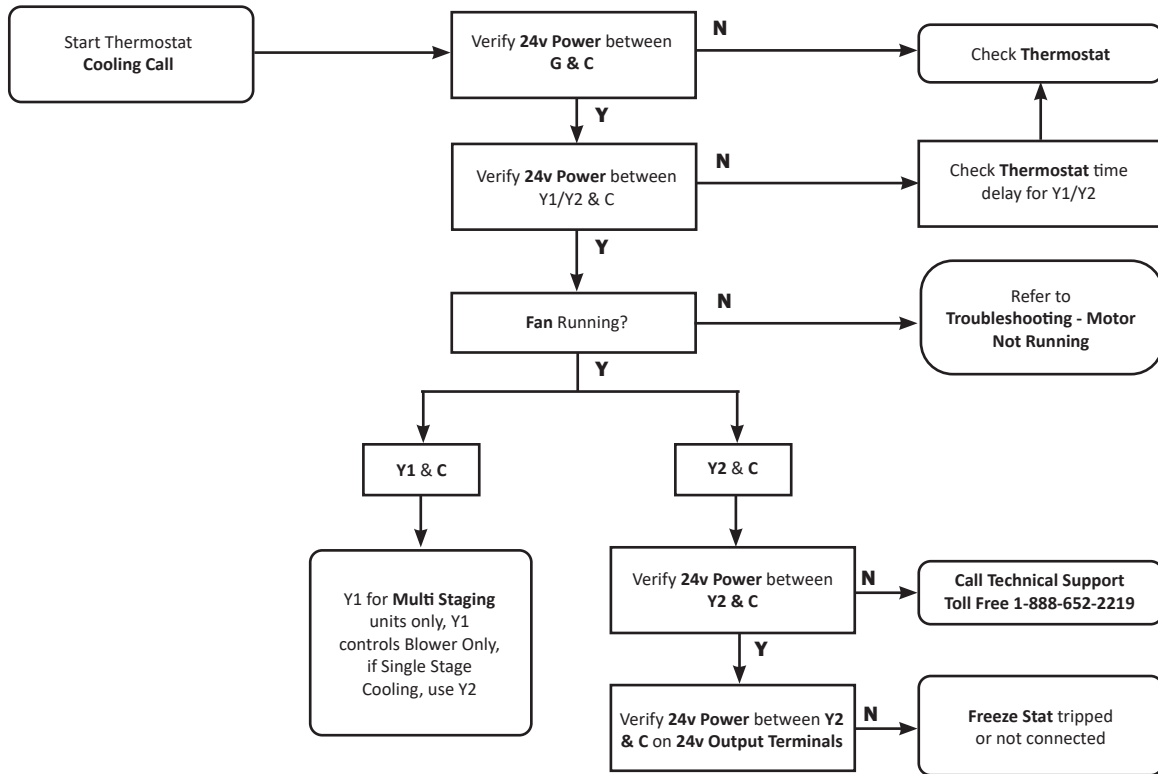

Fig. 007

## Troubleshooting - 24Volt Thermostat to HEB Circuit Board



### Troubleshooting - Cooling 24 Volt Circuit Board



### Trouble Shooting: Heating 24 Volt Circuit Board

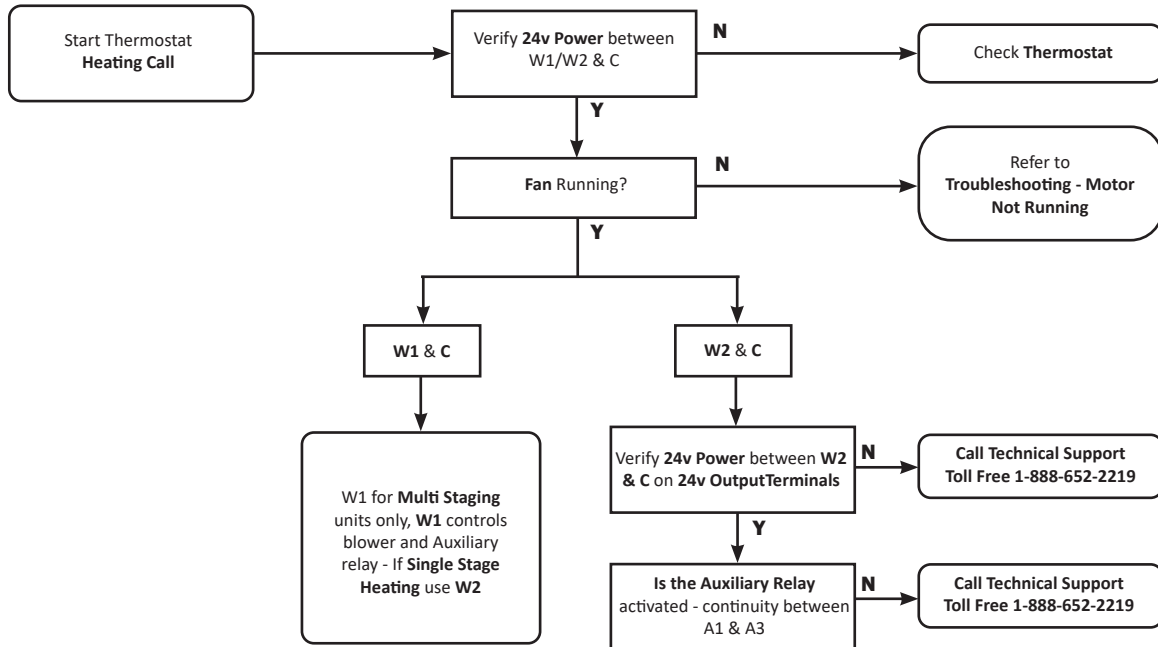

## Troubleshooting - Outdoor Unit - Electrical

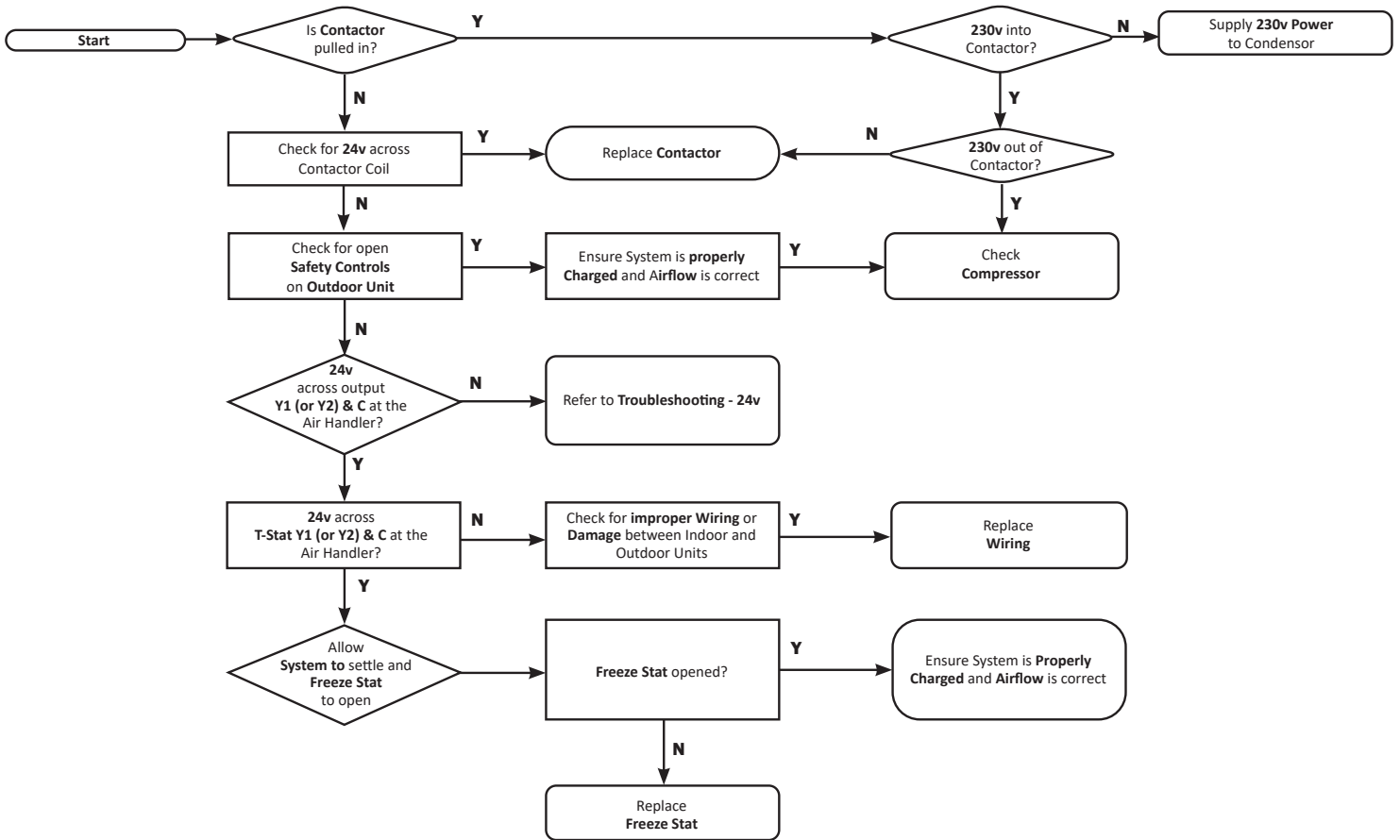

## Troubleshooting - Short Cycling

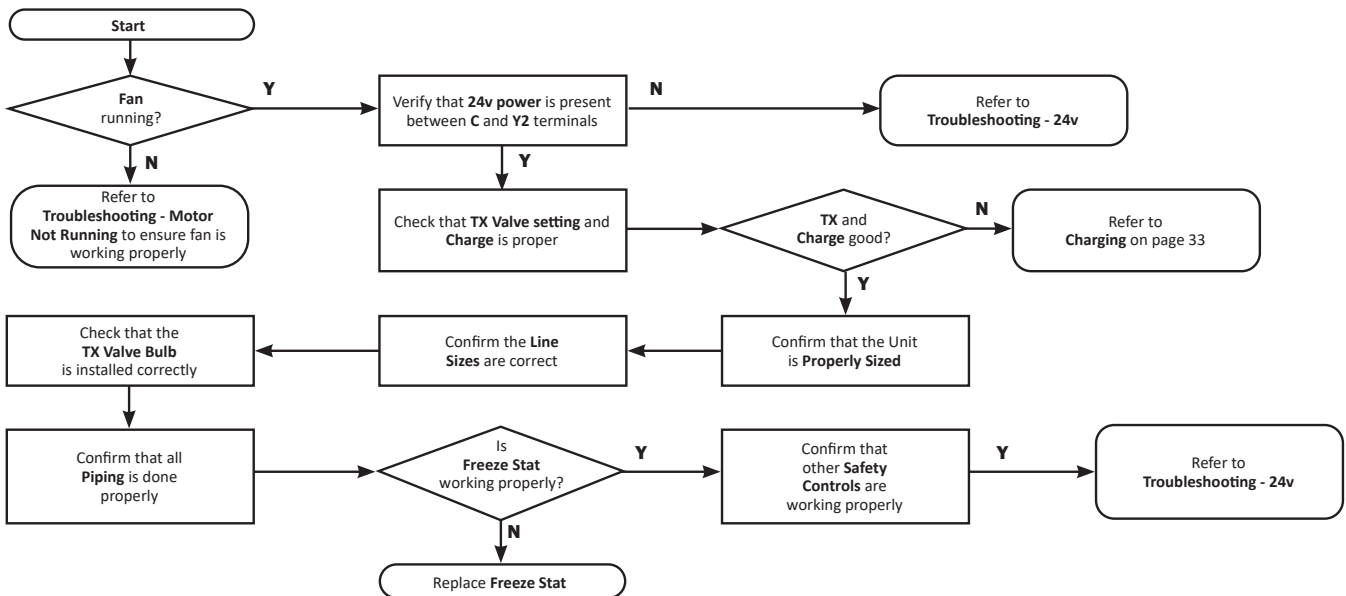



Matching Coils  
Refrigerant Coils  
RBM/RBM-I  
RCM/RCM-I-50, 70, 100  
Chilled Water Coils  
WBM/WCM-50, 70, 100  
Hot Water Coils  
HWC-50, 70, 100  
Electrical Coils  
ESH-650, 750, 1100

# HE-B Series Specifications

Builders Series Air Handler w/ VFD

	HE-B-51	HE-B-71	HE-B-101
<b>Hot Water Heating<sup>(1)</sup></b>	<b>2 Ton Airflow (7.0 kW)</b>	<b>3 Ton Airflow (10.6 kW)</b>	<b>5 Ton Airflow (17.6 kW)</b>
Coil Type	6 Row/10 FPI	6 Row/10 FPI	6 Row/10 FPI
Max. BTUH @ 190°F E.W.T. (kW @ 88°C)	59,400 (17.4 kW)	89,200 (26.1 kW)	134,000 (39.3 kW)
Max. BTUH @ 180°F E.W.T. (kW @ 82°C)	54,500 (16.0 kW)	81,800 (24.0 kW)	122,900 (36.0 kW)
Max. BTUH @ 170°F E.W.T. (kW @ 77°C)	49,600 (14.5 kW)	74,400 (21.8 kW)	111,800 (32.8 kW)
Max. BTUH @ 160°F E.W.T. (kW @ 71°C)	44,600 (13.1 kW)	67,100 (19.7 kW)	100,700 (29.5 kW)
Max. BTUH @ 150°F E.W.T. (kW @ 66°C)	39,700 (11.6 kW)	59,700 (17.5 kW)	89,700 (26.3 kW)
Max. BTUH @ 140°F E.W.T. (kW @ 60°C)	34,700 (10.2 kW)	51,800 (15.2 kW)	78,400 (23.0 kW)
Max. BTUH @ 130°F E.W.T. (kW @ 54°C)	29,700 (8.7 kW)	44,700 (13.1 kW)	67,100 (19.7 kW)
Max. BTUH @ 120°F E.W.T. (kW @ 49°C)	24,800 (7.3 kW)	37,400 (11.0 kW)	56,200 (16.5 kW)
Max. BTUH @ 110°F E.W.T. (kW @ 43°C)	20,100 (5.9 kW)	30,300 (8.9 kW)	45,500 (13.3 kW)
GPM Flow Ratings (L/s Flow Ratings)	5 (0.32 L/s)	7 (0.44 L/s)	10 (0.63 L/s)
Pressure Drop in Ft. H <sub>2</sub> O (Drop in KPa)	3 (8.96 KPa)	6.5 (19.4 KPa)	6.8 (20.3 KPa)
<b>Chilled Water Cooling<sup>(1)</sup></b>	<b>WBM/WCM-50</b>	<b>WBM/WCM-70</b>	<b>WBM/WCM-100</b>
Coil Type	6 Row/10 FPI	6 Row/10 FPI	6 Row/10 FPI
<b>WBM/WCM Modules in Cooling Mode</b>	<b>Total</b>	<b>Sensible</b>	<b>Total</b>
Max. BTUH @ 48°F E.W.T. (kW @ 8.9°C)	19,300 (5.7 kW)	13,700 (4.0 kW)	27,000 (7.9 kW)
Max. BTUH @ 46°F E.W.T. (kW @ 7.8°C)	20,900 (6.1 kW)	14,200 (4.2 kW)	29,400 (8.6 kW)
Max. BTUH @ 44°F E.W.T. (kW @ 6.7°C)	22,600 (6.6 kW)	14,900 (4.4 kW)	31,800 (9.3 kW)
Max. BTUH @ 42°F E.W.T. (kW @ 5.6°C)	24,200 (7.1 kW)	15,700 (4.6 kW)	34,000 (10.0 kW)
Max. BTUH @ 40°F E.W.T. (kW @ 4.4°C)	25,800 (7.6 kW)	16,300 (4.8 kW)	36,400 (10.7 kW)
<b>WBM/WCM Modules in Heating Mode</b>	<b>Total</b>	<b>Total</b>	<b>Total</b>
Max. BTUH @ 150°F E.W.T. (kW @ 66°C)	39,700 (11.6 kW)	59,700 (17.5 kW)	89,700 (26.3 kW)
Max. BTUH @ 140°F E.W.T. (kW @ 60°C)	34,700 (10.2 kW)	51,800 (15.2 kW)	78,400 (23.0 kW)
Max. BTUH @ 130°F E.W.T. (kW @ 54°C)	29,700 (8.7 kW)	44,700 (13.1 kW)	67,100 (19.7 kW)
Max. BTUH @ 120°F E.W.T. (kW @ 49°C)	24,800 (7.3 kW)	37,400 (11.0 kW)	56,200 (16.5 kW)
Max. BTUH @ 110°F E.W.T. (kW @ 43°C)	20,100 (5.9 kW)	30,300 (8.9 kW)	45,500 (13.3 kW)
GPM Flow Ratings (L/s Flow Ratings)	5 (0.32 L/s)	7 (0.44 L/s)	10 (0.63 L/s)
Pressure Drop in Ft. H <sub>2</sub> O (Drop in KPa)	3 (8.97 KPa)	6.5 (19.4 KPa)	6.8 (20.3 KPa)
<b>Refrigerant Cooling<sup>(1)</sup></b>	<b>RBM/RCM-50</b>	<b>RBM/RCM-70</b>	<b>RBM/RCM-100</b>
RBM/RCM Modules BTUH Refrigerant TX Cooling	1.5 - 2.0 Tons (5.3-7.0 kWh)	2.5 - 3.0 Tons (8.8-10.6 kWh)	3.5 - 5.0 Tons (12.3-17.6 kWh)
<b>Electrical Heating</b>	<b>ESH/VESH-650</b>	<b>ESH/VESH-750</b>	<b>ESH/VESH-1100</b>
Kilowatt Range (240v)	5 - 15 kW / 10 - 15 kW	5 - 18 kW / 10 - 18 kW	10 - 23 kW
<b>Specifications</b>	<b>HE-B-51</b>	<b>HE-B-71</b>	<b>HE-B-101</b>
Max Rated CFM @ 1.2" E.S.P. (L/s @ 298 Pa)	500 (236 L/s)	750 (354 L/s)	1250 (590 L/s)
Voltage	115/230/1/50/60 F.L.A. 8 amp	115/230/1/50/60 F.L.A. 8 amp	115/230/1/50/60 F.L.A. 8 amp
Nominal Operating Amperage	4 Amps	6 Amps	8 Amps
Integral Surge and Fuse System	Yes	Yes	Yes
Horse Power - Watts	3/4hp - 310W	3/4hp - 530W	3/4hp - 720W
Motor RPM	Variable	Variable	Variable
Supply Air Size	8" Round (203mm)	8" Round (203mm)	10" Round (254mm)
Supply Maximum Length <sup>(2)</sup>	70' (21.3m)	80' (24.4m)	100' (30.5m)
Return Size Needed	12" (120 in <sup>2</sup> ) (305mm/774cm <sup>2</sup> )	12" (120 in <sup>2</sup> ) (305mm/774cm <sup>2</sup> )	14" (168 in <sup>2</sup> )
Minimum Outlets <sup>(3)</sup>	6 (HE) 12 (2")	10 (HE) 20 (2")	14 (HE) 28 (2")
Maximum Outlets	13 (HE) 26 (2")	18 (HE) 36 (2")	30 (HE) 60 (2")
Shipping Weight (no coil)	69 lbs (31.3 kg)	77 lbs (34.9 kg)	92 lbs (41.7 kg)
Air Handler Size (L x W x H) (Add 2 1/2 inches to height for collars)	14 1/2" x 18 1/4" x 32 5/16" (368mm x 464mm x 821mm)	19 1/2" x 18 1/4" x 32 5/16" (495mm x 464mm x 821mm)	25 1/2" x 18 1/4" x 32 5/16" (648mm x 464mm x 821mm)

<sup>(1)</sup> Heating specs are rated at 68°F E.A.T., Cooling specs are rated at 80°F/67°F dB/wB

<sup>(2)</sup> Maximum length is from the unit to the supply run end cap. More than one run per unit is allowable.

<sup>(3)</sup> Minimum of **four HE outlets per ton** of cooling needed. (2" Duct = Minimum **eight 2" outlets per ton**)

BTUH - British Thermal Units per Hour  
E.W.T. - Entering Water Temperature  
GPM - US Gallons per Minute  
L/s - Litres per Second  
CFM - Cubic Feet per Minute

F.L.A. - Full-Load Amperage  
RPM - Revolutions per Minute  
E.S.P. - External Static Pressure  
E.A.T. - Entering Air Temperature  
dB/wB - Dry Bulb/Wet Bulb

# Quick Sizing Guide

## ALL UNITS

Item	Length	Width	Height
<b>Cube Air Handlers</b>	<b>A</b>	<b>B</b>	<b>C</b>
CU-31	14" (356mm)	13 1/2" (343mm)	14 1/2" (368mm)
CU-51	14" (356mm)	18 1/4" (464mm)	16 1/4" (413mm)
<b>Hi-Velocity Air Handlers</b>	<b>A</b>	<b>B</b>	<b>C</b>
HE-Z/HE-B-50/51	14 1/2" (368mm)	18 1/4" (464mm)	32 5/16" (821mm)
HE-Z/HE-B-70/71	19 1/2" (495mm)	18 1/4" (464mm)	32 5/16" (821mm)
HE-Z/HE-B-100/101	25 1/2" (648mm)	18 1/4" (464mm)	32 5/16" (821mm)
HE-P-240/241	26 3/4" (679mm)	24 1/4" (616mm)	38 3/4" (984mm)
<b>Lo-Velocity Air Handlers</b>	<b>A</b>	<b>B</b>	<b>C</b>
LV-Z/LV-B-750, LV-50	14 1/2" (368mm)	18 1/4" (464mm)	32 5/16" (821mm)
LV-Z/LV-B-1050, LV-70	19 1/2" (495mm)	18 1/4" (464mm)	32 5/16" (821mm)
LV-120/140	25 1/2" (648mm)	18 1/4" (464mm)	32 5/16" (821mm)
LV-Z/LV-B-1750	26 3/4" (679mm)	24 1/4" (616mm)	38 3/4" (984mm)

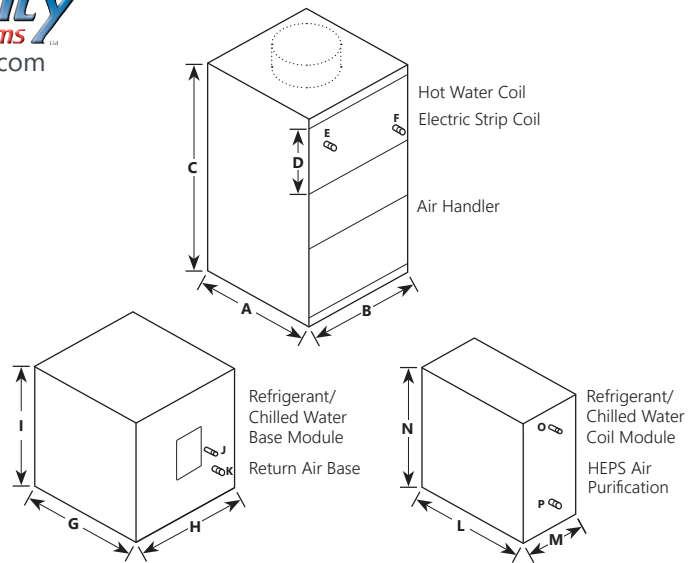

<b>RBM/RBM-I Refrigerant Base Modules</b>		<b>G</b>	<b>H</b>	<b>I</b>	<b>J</b>	<b>K</b>
RBM/RBM-I-50	Fits HE-Z/HE-B/HE/HV-50/51/52, CU-51, LV-Z/LV-B-750/751, LV-50 (1.5 - 2 Tons)	14 1/2" (368mm)	18 1/4" (464mm)	18 1/4" (464mm)	3/8" (RBM-I 1/2")	7/8" (22mm)
RBM/RBM-I-70	Fits HE-Z/HE-B/HE/HV-70/71, LV-Z/LV-B/LV-E-1050/1051, LV-70 (2.5 - 3 Tons)	19 3/8" (492mm)	18 1/4" (464mm)	18 1/4" (464mm)	3/8" (RBM-I 1/2")	7/8" (22mm)
RBM/RBM-I-100	Fits HE-Z/HE-P/HE-B/HE/HV-100/101 (3.5 - 5 Tons), HE-P-240 (x2 Coils 5-10 Tons)	25 3/8" (645mm)	18 1/4" (464mm)	18 1/4" (464mm)	3/8" (RBM-I 1/2")	7/8" (22mm)

<b>RCM/RCM-I Refrigerant Modules</b>		<b>L</b>	<b>M</b>	<b>N</b>	<b>O</b>	<b>P</b>
RCM-30	Fits JH 15/30, CU-31 (1 Ton)	14 3/8" (365mm)	12 1/4" (311mm)	12 3/8" (314mm)	3/8" (9.5mm)	5/8" (15.9mm)
RCM/RCM-I-50	Fits HE-Z/HE-B/HE/HV-50/51/52, CU-51, LV-Z/LV-B-750/751, LV-50 (1.5 - 2 Tons)	14 3/8" (365mm)	10 1/8" (257mm)	18 1/2" (470mm)	1/2" (13mm)	7/8" (22mm)
RCM/RCM-I-70	Fits HE-Z/HE-B/HE/HV-70/71, LV-Z/LV-B/LV-E-1050/1051, LV-70 (2.5 - 3 Tons)	19 3/8" (492mm)	10 1/8" (257mm)	18 1/2" (470mm)	1/2" (13mm)	7/8" (22mm)
RCM/RCM-I-100	Fits HE-Z/HE-P/HE-B/HE/HV-100/101 (3.5 - 5 Tons), HE-P-240 (x2 Coils 5-10 Tons)	25 3/8" (645mm)	10 1/8" (257mm)	18 1/2" (470mm)	1/2" (13mm)	7/8" (22mm)

<b>WBM Chilled Water Base Modules</b>		<b>G</b>	<b>H</b>	<b>I</b>	<b>J</b>	<b>K</b>
WBM-50	Fits HE-Z/HE-B/HE/HV-50/51/52, CU-51, LV-Z/LV-B-750/751, LV-50	14 1/2" (368mm)	18 1/4" (464mm)	18 1/4" (464mm)	3/4" (19mm)	3/4" (19mm)
WBM-70	Fits HE-Z/HE-B/HE/HV-70/71, LV-Z/LV-B/LV-E-1050/1051, LV-70	19 3/8" (492mm)	18 1/4" (464mm)	18 1/4" (464mm)	3/4" (19mm)	3/4" (19mm)
WBM-100	Fits HE-Z/HE-P/HE-B/HE/HV-100/101, LV-Z/LV-B/LV-E-1050/1051, LV-120/140	25 3/8" (645mm)	18 1/4" (464mm)	18 1/4" (464mm)	3/4" (19mm)	3/4" (19mm)

<b>WCM/WM Chilled Water Modules</b>		<b>L</b>	<b>M</b>	<b>N</b>	<b>O</b>	<b>P</b>
WCM-50	Fits HE-Z/HE-B/HE/HV-50/51/52, CU-51, LV-Z/LV-B-750/751, LV-50	14 3/8" (365mm)	10 1/8" (257mm)	18 1/2" (470mm)	3/4" (19mm)	3/4" (19mm)
WCM-70	Fits HE-Z/HE-B/HE/HV-70/71, LV-Z/LV-B/LV-E-1050/1051, LV-70	19 3/8" (492mm)	10 1/8" (257mm)	18 1/2" (470mm)	3/4" (19mm)	3/4" (19mm)
WCM-100	Fits HE-Z/HE-P/HE-B/HE/HV-100/101, LV-Z/LV-B/LV-E-1050/1051, LV-120/140	25 3/8" (645mm)	10 1/8" (257mm)	18 1/2" (470mm)	3/4" (19mm)	3/4" (19mm)
WM-1750	Fits LV-Z/LV-B/LV-E-1750/1751	26 1/4" (667mm)	8 1/4" (209mm)	22 5/8" (575mm)	1" (25mm)	1" (25mm)

<b>HWC Hot Water Coils</b>		<b>A</b>	<b>B</b>	<b>D</b>	<b>E</b>	<b>F</b>
HWC-30	Fits CU-31, JH-15/30	13 1/2" (343mm)	12 1/2" (317mm)	3 3/8" (85mm)	3/8" (9.5mm)	3/8" (9.5mm)
HWC-50	Fits HE-Z/HE-B/HE/HV-50/51, CU-51, LV-Z/LV-B-750/751, LV-50	13 1/2" (343mm)	16" (406mm)	5 1/2" (140mm)	3/4" (19mm)	3/4" (19mm)
HWC-70	Fits HE-Z/HE-B/HE/HV-70/71, LV-Z/LV-B/LV-E-1050/1051, LV-70	19" (483mm)	16" (406mm)	5 1/2" (140mm)	3/4" (19mm)	3/4" (19mm)
HWC-100	Fits HE-Z/HE-P/HE-B/HE/HV-100/101, LV-120/140	25" (635mm)	16" (406mm)	5 1/2" (140mm)	3/4" (19mm)	3/4" (19mm)
HWC-1750	Fits HE-P-240/241, LV-Z/LV-B/LV-E-1750/1751	26" (660mm)	22" (559mm)	6" (152mm)	1" (25mm)	1" (25mm)

Heating Coil Add-on does not come as a module, it slides into the Hi-Velocity Air Handler. Comes installed in all "H" Air Handlers.

<b>ESH/VESH Electrical Strip Heater</b>		<b>A</b>	<b>B</b>	<b>D</b>
VESH-400 (5 kW)	Fits CU-31	13 3/4" (349mm)	12 1/8" (308mm)	5 5/8" (143mm)
VESH/ESH-650 (5-15 kW)	Fits HE-Z/HE-B/HE/HV-50/51, LV-Z/LV-B-750/751, LV-50	13 3/4" (349mm)	17" (432mm)	5 5/8" (143mm)
VESH/ESH-750 (5-18 kW)	Fits HE-Z/HE-B/HE/HV-70/71, LV-Z/LV-B/LV-E-1050/1051, LV-70	18 3/4" (476mm)	17" (432mm)	5 5/8" (143mm)
VESH/ESH-1100 (10-23 kW)	Fits HE-Z/HE-P/HE-B/HE/HV-100/101, LV-120/140	24 3/4" (629mm)	17" (432mm)	5 5/8" (143mm)
VESH/ESH-2500 (10-25 kW)	Fits HE-P-240 BU, LV-Z-1750/1751 BU	25 3/4" (654mm)	21 7/8" (556mm)	6" (152mm)

Dimensions for the ESH do not include the electrical access panel, add 4" to Length (6" for 2500)

<b>HEPS Hi-Velocity Air Purification System (See parts list for replacement filters)</b>		<b>L</b>	<b>M</b>	<b>N</b>
HEPS w/ Merv 13 Filt.	Fits All 50/51/70/71/750/751/100/101/120/140/1050 Units	26 1/16" (662mm)	10 5/16" (262mm)	18 3/8" (467mm)
HEPS-1750 w/ Merv 13	Fits HE-P-240/241, LV-Z/LV-B/LV-E-1750/1751	28 1/2" (723mm)	10 5/16" (262mm)	21 1/8" (537mm)

<b>Return Air Base</b>		<b>G</b>	<b>H</b>	<b>I</b>
RA-50	Fits HE-Z/HE-B/HE/HV-50/51, CU-51, LV-Z/LV-B-750/751, LV-50	14 1/2" (368mm)	18 1/2" (470mm)	22 1/2" (572mm)
RA-70	Fits HE-Z/HE-B/HE/HV-70/71, LV-Z/LV-B/LV-E-1050/1051, LV-70	19 1/2" (495mm)	18 1/2" (470mm)	22 1/2" (572mm)
RA-100	Fits HE-Z/HE-P/HE-B/HE/HV-100/101, LV-120/140	25 1/2" (648mm)	18 1/2" (470mm)	22 1/2" (572mm)
RA-1750	Fits HE-P-240/241, LV-Z/LV-B/LV-E-1750/1751	26 1/2" (673mm)	24 1/2" (622mm)	24" (610mm)

<b>HVS Series Variable Speed Heat Pump</b>		<b>Length</b>	<b>Width</b>	<b>Height</b>
HVS-24	Can be used with HE-Z/HE-B/HE/HV-50/51, CU-51, LV-Z/LV-B-750/751, LV-50	38" (965mm)	16.14" (410mm)	32" (813mm)
HVS-36	Can be used with HE-Z/HE-B/HE/HV-70/71, LV-Z/LV-B/LV-E-1050/1051	38" (965mm)	16.14" (410mm)	32" (813mm)
HVS-60	Can be used with HE-Z/HE-P/HE-B/HE/HV-100/101, LV-120/140	37.5" (953mm)	16.25" (413mm)	52.5" (1,334mm)



Energy Saving Products Ltd, established in 1983, manufactures the Hi-Velocity Systems™ product line for residential, commercial and multi-family markets. Our facilities house Administration, Sales, Design, Manufacturing, as well as Research & Development complete with an in-house test lab. Energy Saving Products prides itself on Customer Service and provides design services and contractor support.

For all of your Heating, Cooling and Indoor Air Quality needs, the Hi-Velocity System is the right choice for you!



Small Duct Heating, Cooling and IAQ Systems

## Build Smart, Breathe *Easy*

Hi-Velocity HE-Z Air Handlers, *Green* Technology



Phone: 780-453-2093  
Fax: 780-453-1932  
Toll Free: 1-888-652-2219

[www.hi-velocity.com](http://www.hi-velocity.com)