



---

# ESH - Electric Strip Heater

## Installation Manual

---



**ESH-650 (5, 10, 15 kW)**  
**ESH-750 (5, 10, 15, 18 kW)**  
**ESH-1100 (10, 15, 18, 20, 23 kW)**  
**ESH-2500 (10, 15, 20, 25 kW)**

### Features:

- Add-on to HE-Z/HE-B/LV-Z/LV-B/LV/CU Series
- 5 kW to 25 kW
- 15 kW and above can be used for 2 stage heat
- Easily slides into heating section of BU Series
- Pre-wired elements electronically controlled
- High-Limit thermal protection
- Approved for zero clearance to combustible materials

### Includes:

- Install manual
- ESH Coil door (HE-Z/HE-Z/Zoning/HE-B & LV Units)
- Hardware (Neoprene, Screws, 1' length of t-stat wire, plugs)

## Electrical Strip Heater



The Electrical Strip Heater (ESH) is an electric resistance heater that slides into the air handler on the leaving air side (supply side) of the blower. This heater can be used for primary heating or supplemental heat (auxiliary heating) for heat pumps. The ESH has "0" clearance to combustibles, and requires minimum clearances on the access side for maintenance and servicing (see Air Handler Placement: Module FCP). Allow 18" minimum of straight plenum duct from the supply of the air handler before any branch outlets, tees or elbows.

There is a minimum airflow/outlet requirement for electric strip heaters. Refer to chart:

### Minimum # of Outlets Required (Airflow)

Model	5 kW	10 kW	15 kW	18/20 kW	23/25 kW
CU-51	10 HE 20 2"	10 HE 20 2"	10 HE 20 2"	N/A	N/A
HE-Z/B 50/51	6 HE 12 2"	6 HE 12 2"	10 HE 20 2"	N/A	N/A
HE-Z/B 70/71	10 HE 20 2"	10 HE 20 2"	10 HE 20 2"	12 HE 24 2"	N/A
HE-Z/B 100/101	N/A	14 HE 28 2"	14 HE 28 2"	16 HE 32 2"	20 HE 40 2"
HE-P 240/241	N/A	28 HE 56 2"	28 HE 56 2"	28 HE 56 2"	28 HE 56 2"

## Installation

Remove the shipping covers and inspect the heater carefully. Check the ESH for any shipping damage, check the heating elements for any loose connections and check all porcelain insulators for any breaks. Report any damage to the manufacturer. **DO NOT INSTALL DAMAGED HEATER.**



The ESH is labeled with a directional airflow sticker; when placing the ESH, the sticker shall be in the direction of the air flow.

Install the ESH in the supply air side of the air handler. Follow directions on the cut-out template pages included with the coil, or install the provided ESH door on air handler for easy slide-in installation of the ESH. The heating elements (Fig. 01) must always be installed horizontally. Seal the void between the air handler and the ESH with foam tape or a suitable sealant. Mount the ESH onto the air handler cabinet with 4 self tapping screws from inside the ESH wiring access door. Seal any additional openings with foil tape or a suitable sealing compound.

Fig. ESH-01 - Do not install elements Vertically

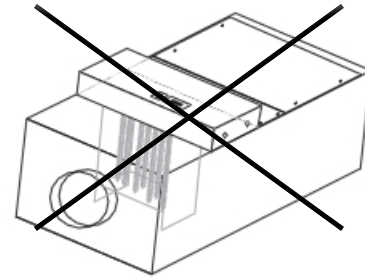

Do not install ESH as shown, with controls on top

## Wiring the Electrical Strip Heater

The air handler and the ESH must have independent power supplies. **Disconnect all power sources before opening the control box and working within.** Wires shall be sized according to local electrical codes and ordinances. All wires must be brought in through knock-outs. See Table ESH-01 for feeder quantity of feeder ampacity.

Table ESH-01

Kw	Volts/Phase	# of feeders	Circuit Breakers
5	240/1	1 X 20.8	1 X 30A
10	240/1	1 X 41.6	1 X 60A
15	240/1	1 X 20.8, 1 X 41.6	1 X 30A, 1 X 60A
18	240/1	1 X 31.2, 1 X 41.6	1 X 40A, 1 X 60A
20	240/1	2 X 41.6	2 X 60A
23	240/1	2 X 47.0	2 X 60A
25	240/1	2 X 41.6, 1 X 20.8	2 X 60A, 1 X 40A

**PLEASE NOTE: THE ESH MUST BE WIRED TO A DEDICATED BREAKER, SEPARATE FROM THE AIR HANDLER.**

The ESH elements are rated for 240V 60 Hz. Higher voltages are not recommended. When lower voltages are supplied, de-rate the capacity of the ESH accordingly. 230V = 92%, 220V = 84%, 208V = 75%. Use only wires suitable for 167° F (75°C).

The ESH 5 and 10 kW units have one single 240V breaker; the 15 kW to 23 kW units come complete with two supply circuit breakers. These two circuits can be joined together using a Jumper Bar (Square D® – QOU14100JBAF, not supplied) designed to use one pair of larger gauge wire instead of two smaller gauge wires. Install as per manufacturers guide lines, and according to code. A disconnect switch close to the heater will be required.

Control circuit wiring between the heater terminals #1 and #2 on the ESH use Class 2 - 18 gauge wire to the zone valve terminals in the fan control box.

## Operation

**The low voltage signals that energize the ESH come from the air handler's zone valve terminals (W1/W2 output and C). These are to be connected to #1 and #2 of the ESH.** Note: This connection is polarity sensitive. The W2 output is energized with 24v with a call for heat from a W2 call on the air handler's terminal board. W2 will also energize the heating fan speed on the air handler. For air handler to ESH low voltage wiring, see next page. High voltage wiring of the ESH can be viewed on the inside of the ESH front panel.

On a demand for heat the TH-24 electronic sequencer will energize the heating elements in sequence. When the thermostat is satisfied, all the elements and blower will be de-energized.

Within the ESH, there are automatic reset thermal cut-out disc type safety devices at a fixed temperature that open the control circuit when a set point is reached. When the overheating conditions have disappeared, it automatically resets and returns the heater to normal operating conditions.

## Zoning

**The standard off the shelf ESH has 2 stages and therefore can be used with a maximum of 2 zones.** Energy Saving Products Ltd. also offers a special electric strip module (VESH) for increased zoning capabilities. Please contact the factory for additional information.

## Maintenance

ESH heaters have been designed to operate long term without issue. Those responsible for equipment and maintenance should be aware of the following suggestions:

**Periodic visual inspection:** This precautionary step will help to keep your unit operating properly. Inspect the unit periodically and be on the lookout for any first signs of problems: Accumulation of dust on the heating elements, signs of overheating on the heater frame, traces of water or rust on the control box.

**Electrical inspection:** Two weeks after start up, all electric connections to contactors should be re-checked and tightened. Before each heating season, the following steps are recommended:

- Check all fuses
- Check resistance to ground for each circuit
- Check resistance phase to phase for each circuit
- Check the tightness of connections at all contactors and heating elements
- Check all contactors
- Check electrical connections to heating elements, magnetic contactors, and main power plugs.

It is recommended that this inspection be performed monthly for the first four months of operation. Following that, two inspections per heating season is sufficient.

## Off Season Maintenance

Should a heater be shut off for a long period, we recommend that you carefully check the resistance to ground for each circuit. It is important not to power a heater when too low a resistance to ground has been measured. It is also recommended to pay attention to any other heater operating in normal conditions. All control components should be maintained and checked according to respective manufacturer's instructions. Any defective components should be replaced only with identical origin parts.

Specifications	ESH - 650	ESH - 750	ESH - 1100	ESH-2500
Part Number	5 kW - 10025650005	5 kW - 10025750005	10 kW - 10025110010	10 kW - 10025250010
	10 kW - 10025650010	10 kW - 10025750010	15 kW - 10025110015	15 kW - 10025250015
	15 kW - 10025650015	15 kW - 10025750015	18 kW - 10025110018	20 kW - 10025250020
		18 kW - 10025750018	20 kW - 10025110020	25 kW - 10025250025
			23 kW - 10025110023	
Matching Air Handler	HE-Z/HE-B/HE/ HV-50/51 BU, CU-51 BU, LV-Z/LV-B-750/751 BU, LV-50 BU	HE-Z/HE-B/HE/ HV-70/71 BU LV-Z/LV-B-1050/1051 BU LV-70 BU	HE-Z/HE-B/HE/ HV-100/101 BU LV-120/140 BU	HE-P-240 BU, LV-Z-1750 BU
Volts	240	240	240	240
Phase	1	1	1	1
Shipping Weight	21 lbs (9.5 kg)	27 lbs (12.2 kg)	28 lbs (12.7 kg)	30 lbs (13.6 kg)
Coil Dimensions <sup>(1)</sup> (L x W x H)	13 3/4" x 5 5/8" x 17" (349mm x 143mm x 432mm)	18 3/4" x 5 5/8" x 17" (476mm x 143mm x 432mm)	24 3/4" x 5 5/8" x 17" (629mm x 143mm x 432mm)	25 3/4" x 6" x 21 7/8" (654mm x 152mm x 556mm)

(1) Dimensions for the ESH do not include the electrical access panel, add 4" to ESH for Total Length

## PSB Circuit Board/CFW300 WEG Wiring Diagram

PLEASE NOTE: CFW10 has slightly different appearance, terminals and wiring are the same.

- THERMOSTAT CONNECTIONS**
- R - 24 VAC OUTPUT
  - W1 - FIRST STAGE HEAT
  - W2 - SECOND STAGE HEAT
  - Y1 - FIRST STAGE COOLING
  - Y2 - SECOND STAGE COOLING
  - (OR SINGLE STAGE)
  - G - 24 VAC COMMON
  - C - THERMOSTAT FAN SWITCH
  - D - PRIORITY (RUNS AT W SPEED)
  - O/B - HEATPUMP REVERSING
- EMERGENCY DISCONNECT**
- C - 24 VAC COMMON
  - C - 24 VAC COMMON
  - R0 - 24 VAC OUTPUT
  - R1 - 24 VAC OUTPUT
- AUXILIARY HEATING RELAY**
- N - NEUTRAL
  - L - LINE VOLTAGE
  - A1 - AUXILIARY NORMALLY OPEN
  - A2 - AUXILIARY NORMALLY CLOSED
  - A3 - AUXILIARY COMMON
- 24 VAC OUTPUT CONNECTIONS**
- FZ - FREEZE STAT
  - W1 - HEATING (W1) 24 VAC OUTPUT
  - W2 - HEATING (W2) 24 VAC OUTPUT
  - Y2 - CONDENSING UNIT 24 VAC OUTPUT
  - C - 24 VAC COMMON
  - R - 24 VAC OUTPUT
- JUMPER PIN SETTINGS**
- H1 EMERGENCY DISCONNECT: REMOVE PIN IF WIRED TO EMERGENCY DISCONNECT
  - H2 TIMER: AUXILIARY RELAY TIMER (SEE NOTES)
  - H3 MODE:
    - AUTO - FAN SPEED MODULATES DEPENDING UPON STATIC PRESSURE
    - MANUAL - FAN SPEED OPERATES AT TRIM POTS SET AIR FLOW
    - H4 DELAY: 1/20 AND W/30 SECOND FAN DELAY. Y AND W 30 SECOND POST PURGE.
- LED LIGHT INDICATORS**
- LED 1 - GREEN LIGHT, PUMP TIMER OPERATION MODE INDICATOR
  - LED 2 - BLUE LIGHT, PRESSURE SENSOR

**CAUTION**  
FOR SINGLE STAGE COOLING OPERATION USE Y2 OTHERWISE THE FREEZE STAT WILL BE BYPASSED

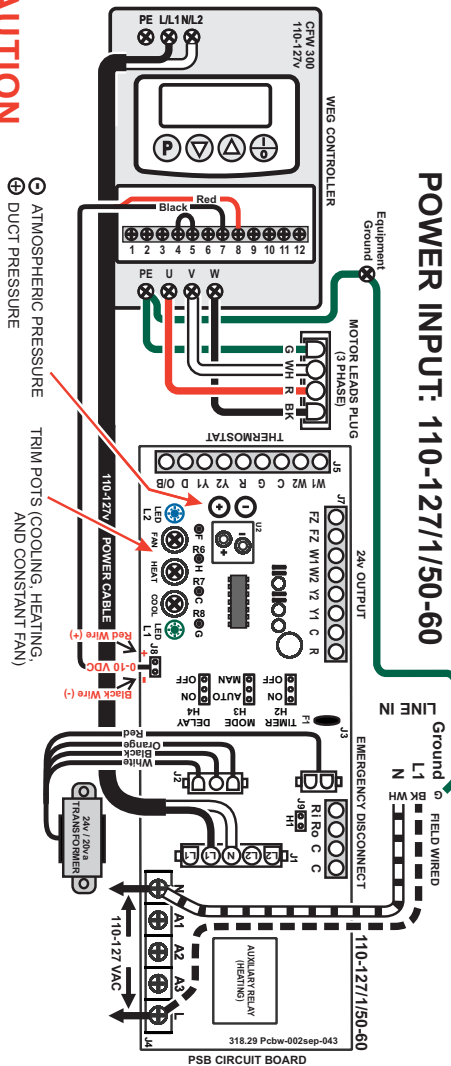

**POWER INPUT: 110-127/1150-60**

- ⊕ ATMOSPHERIC PRESSURE
- ⊕ DUCT PRESSURE
- ⊕ TRIM POTS (COOLING, HEATING, AND CONSTANT FAN)

**POWER INPUT: 208-240/1150-60**

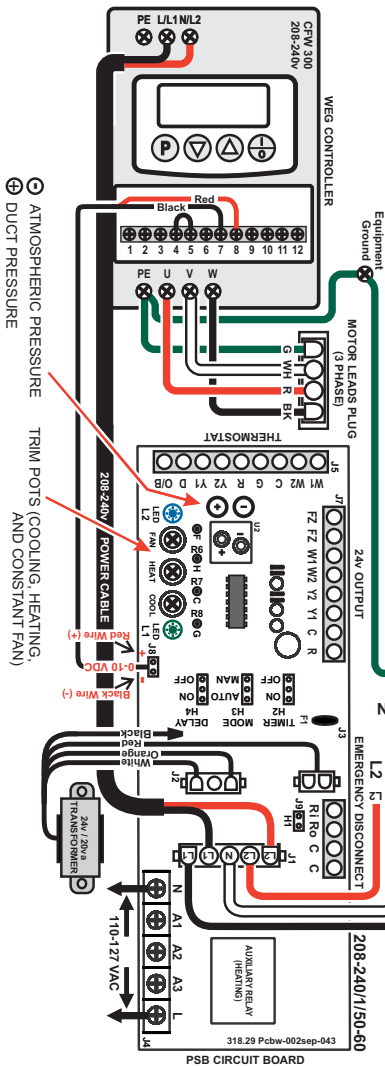

- ⊕ ATMOSPHERIC PRESSURE
- ⊕ DUCT PRESSURE
- ⊕ TRIM POTS (COOLING, HEATING, AND CONSTANT FAN)

Neutral wire (N) only needed when 110v is required from the L and N terminals (J4)

- NOTES:**
- USE THERMOSTAT FAN SWITCH TO DISABLE/ENABLE CONTINUOUS FAN.
  - 'C' TERMINAL ON THERMOSTAT (COMMON) IS NOT NEEDED FOR SOME THERMOSTATS CONSULT THERMOSTAT INSTRUCTIONS FOR DETAILS.
  - W1 AND W2 ACTIVATES AUXILIARY RELAY (A3) ON CALL AND CAN BE USED WITH A1 AND/OR A2 AS DRY CONTACTS. ARMED 24VAC FROM THE 'R' TERMINAL. OR ARMED 110V FROM THE 'L' TERMINAL.
  - AUXILIARY HEATING RELAY TIMER ACTIVATES CIRCUIT FOR 5 MINUTES EVERY 24 HOURS STARTING WHEN POWER IS APPLIED TO THE UNIT.
  - LED 1: INDICATOR LIGHT FOR FAN SPEED OPERATION AND AUXILIARY RELAY OPERATION. SEE BELOW FOR LIGHT OPERATION SEQUENCE.
  - SEE INSTALLATION MANUAL FOR MORE DETAILED WIRING DIAGRAMS.
  - FOR SINGLE STAGE COOLING OPERATION USE Y2, OTHERWISE THE FREEZE STAT WILL BE BYPASSED.**
  - FAILURE TO SET PROPER AIR FLOW AND/OR OPERATION OF THE SYSTEM MAY RESULT IN DAMAGE TO EQUIPMENT.
  - FAILURE TO READ AND FOLLOW ALL INSTRUCTIONS CAREFULLY BEFORE INSTALLATION COULD CAUSE PERSONAL INJURY AND/OR PROPERTY DAMAGE.
  - ENSURE THAT THE FILTER IS KEPT CLEAN AT ALL TIMES.
  - MOTOR HAS PERMANENT LUBE BEARINGS AND DOES NOT REQUIRE OILING.
  - WARRANTY VOID IF FAN COIL UNIT IS USED DURING CONSTRUCTION.

PUMP TIMER STATUS	FAN OPERATION MODE
ON: (ACTIVE)	G
ON: (INACTIVE)	W
OFF:	Y
	D
2 SECONDS	2 SECONDS

- LED 1: (GREEN LIGHT)**  
PUMP TIMER/OPERATION MODE INDICATOR LIGHT SEQUENCE
- LED 2: PRESSURE SENSING INDICATOR (BLUE LIGHT)**
- H3 JUMPER PIN: AUTO OR MANUAL MODE**  
AUTO MODE: LED 2 WILL SPORADICALLY FLICKER (ON/OFF) TO SHOW THAT IT IS PROPERLY SENSING PRESSURE IN THE SYSTEM.  
\* NO LIGHT INDICATES TRIM POT IS ABOVE NORMAL OPERATING RANGE (COUNTER CLOCKWISE DECREASE).  
\* SOLID LIGHT INDICATES TRIM POT IS BELOW NORMAL OPERATING RANGE (CLOCKWISE, INCREASE).  
MANUAL MODE: LED 2 WILL BE OFF. ADJUST EACH OF THE AIR FLOWS TO DESIRED CFMLPS OUTPUT.

- ADJUSTING TRIM POTS: ON POWER START UP ALLOW 45 SECONDS FOR SYSTEM TO PRESSURIZE BEFORE MAKING ANY CHANGES.**  
DO NOT ADJUST MORE THAN A 1/2 TURN AT A TIME. ALLOW 30 SECONDS BETWEEN ADJUSTMENTS FOR THE PSB TO REACH SET POINT.
- FAN ADJUSTMENT TRIM POTS**
- ⊕ INCREASE AIR FLOW (CLOCKWISE)
  - ⊕ DECREASE AIR FLOW (COUNTER CLOCKWISE)

REFER TO COMPLETE COMMISSIONING REPORT PRIOR TO NORMAL OPERATION. REPORT IS AVAILABLE WITH THE INSTALLATION MANUAL OR ONLINE AT [WWW.HI-VELOCITY.COM](http://WWW.HI-VELOCITY.COM)

### Extended Wiring Diagrams

Extended wiring diagrams for various applications. If you do not find the wiring configuration you require, please call the technical department at Energy Saving Products Ltd. for further assistance.

## HEAT PUMP C/W CONDENSER DEFROST CYCLE ELECTRIC BACK-UP

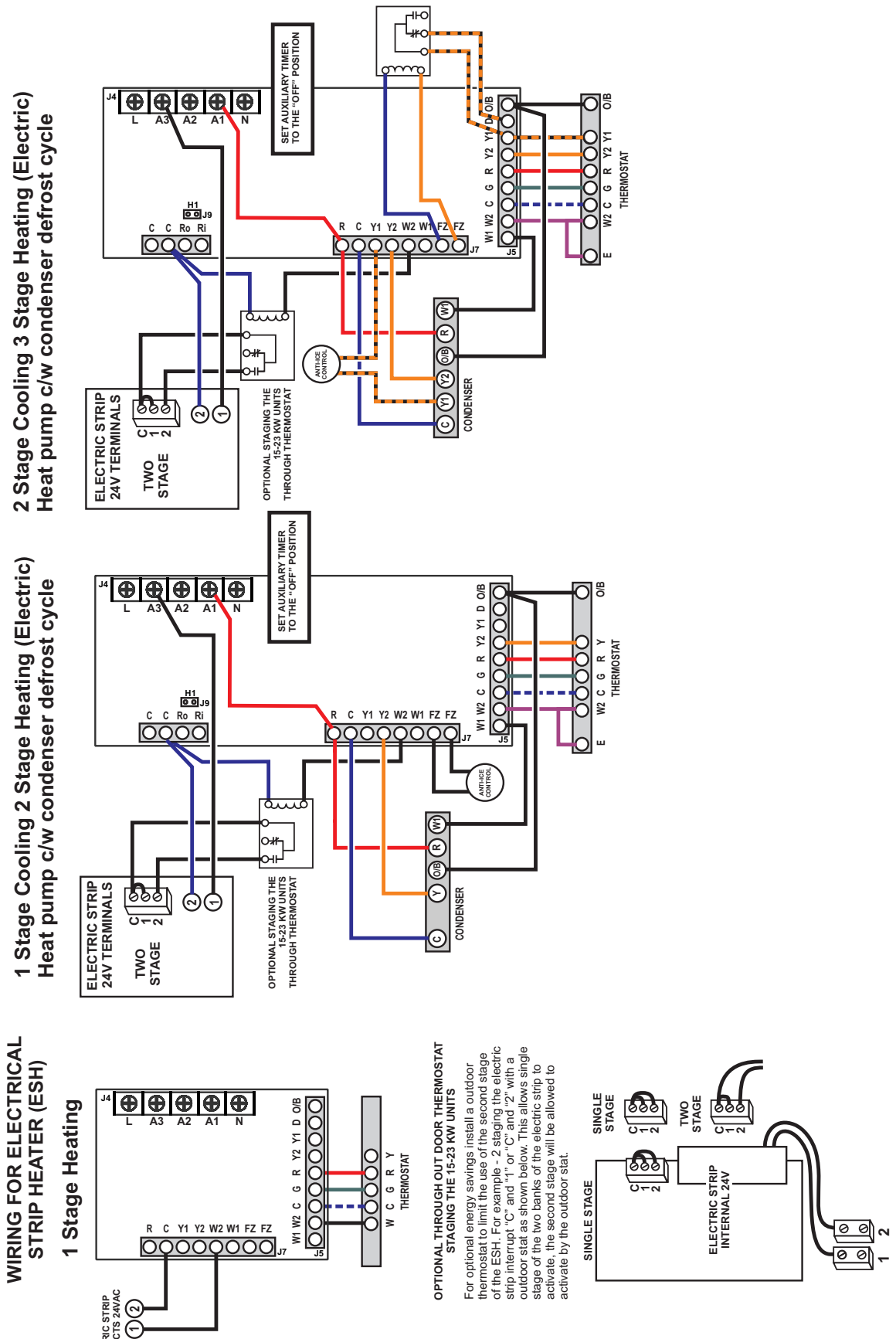

HE-Z-LV-Z-Extended-Wiring-Pg-3-082615

**OPTIONAL THROUGH OUT DOOR THERMOSTAT STAGING THE 15-23 KW UNITS**  
For optional energy savings install a outdoor thermostat to limit the use of the second stage of the ESH. For example -- 2 staging the electric strip interrupt "C" and "1" or "C" and "2" with a outdoor stat as shown below. This allows single stage of the two banks of the electric strip to activate, the second stage will be allowed to activate by the outdoor stat.

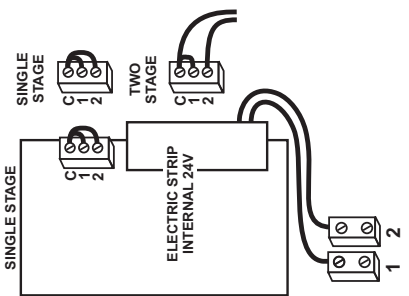

Energy Saving Products Ltd, established in 1983, manufactures the Hi-Velocity Systems™ product line for residential, commercial and multi-family markets. Our facilities house Administration, Sales, Design, Manufacturing, as well as Research & Development complete with an in-house test lab. Energy Saving Products prides itself on Customer Service and provides design services and contractor support.

For all of your Heating, Cooling and Indoor Air Quality needs, the Hi-Velocity System is the right choice for you!



Small Duct Heating, Cooling and IAQ Systems

## Build Smart, Breathe *Easy*

Hi-Velocity HE-Z Air Handlers, **Green** Technology



Phone: 780-453-2093

Fax: 780-453-1932

Toll Free: 1-888-652-2219

[www.hi-velocity.com](http://www.hi-velocity.com)