



www.hi-velocity.com

HVS

Variable Speed Heat Pump



2 Ton
HVS-24



3 Ton
HVS-36



5 Ton
HVS-60

Installation and Operation

From the Manufacturers of
Hi-Velocity Systems™
www.hi-velocity.com

HVS Variable Speed Heat Pump

HVS Series Inverter Drive Variable Speed Heat Pumps are ideally suited for any application. When used with the HE-Z Series, the system modulates refrigerant flow and indoor air flow to precisely match output capacity to load. The ability to match output capacity to load results in superior energy performance not just at the ANSI/AHRI Standard test conditions but right through the entire operational range.

Fixed speed and 2-staged condensing units are not well suited for constantly changing load requirements and multizone applications due to their inability to reduce capacity below 70%. These systems overcome the problem by running the indoor fan at high flow rates and dumping or bypassing excess air. This strategy wastes energy, reduces efficiencies and sacrifices comfort in exchange for a properly functioning system.

The HVS Variable Speed Heat Pump in conjunction with the HE-Z Series Air Handler solves this ongoing issue. The outdoor unit (inverter) monitors indoor coil (evaporator) conditions to maintain a steady air off temperature. No matter the load or number of zones open, the Variable Speed Heat Pump will adjust refrigerant flow or capacity to match these everchanging conditions.

HVS Location Selection

- The outdoor unit must be installed level, in a properly supported outdoor location that is adequately ventilated. Avoid installing outdoor unit on walkways and patios.
- Outdoor unit should be installed using the rubber vibration isolation feet that were supplied with the outdoor unit.
- It is good practice to secure the outdoor unit to its footings or base. If unit is to sit on an equipment riser, stand or hanger, it must be properly secured.
- Locate the outdoor unit as close as possible to the indoor unit. Ensure minimum and maximum lineset lengths meet the min/max length specifications on page 4.
- Outdoor unit should be installed in a location that can maintain the clearances specified on page 3 to ensure proper airflow/heat exchange and maintenance space.
- Must be elevated above the Annual Snow Accumulation Level or average snow fall depths.
- Make sure the piping/lineset vertical height drops do not exceed the allowable value specified on page 4.
- Locate the outdoor unit where the noise, vibration and outlet air does not disturb residence, occupants or neighbors.
- Ensure the air inlet or outlet is not impeded and does not face strong/prevaling winds.

HVS Location Selection Cont'd

- Avoid locating the outdoor unit in a location that is severely dirty, polluted, or contaminated (e.g. close to a dryer vent or under a tree) to avoid blockage of the heat exchanger. If it is, maintenance or cleaning may be needed more than bi-annually.
- If the outdoor unit is installed under an overhang or in an enclosure to protect it from direct sunlight, rain exposure, snow, or strong winds, ensure it still maintains the needed clearances and avoid roof driplines.

Clearances

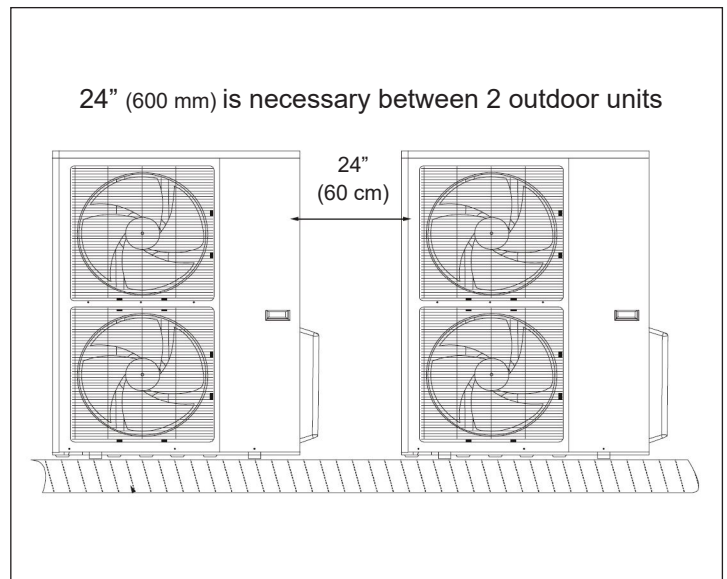
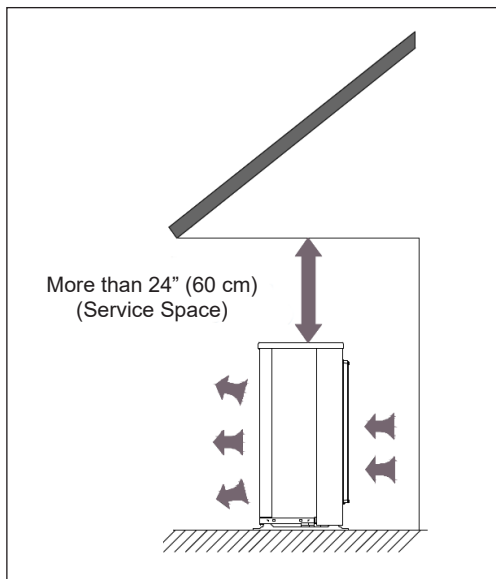
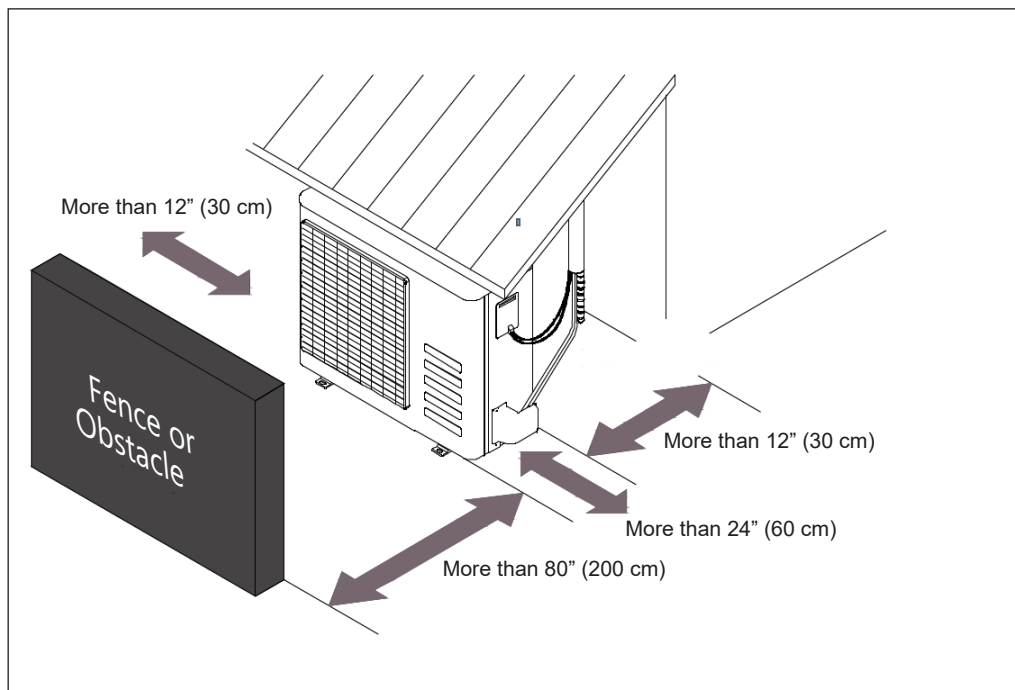

Refrigeration Circuit

Important: Pipe Insulation (min. 3/8") MUST be used on both liquid and suction lines. Ensure insulation covers the entire line set, including flare fittings & penetrations.

- The Electronic Expansion Valve is internal to the HVS Variable Speed Heat Pump, therefore a TXV at the evaporator (indoor unit) is not needed.
- Maximum pipe length for the HVS-24 is 164.5' (50 m), for the HVS-36 and HVS-60 is 213 ft (65 m). Lines must be sized correctly to ensure that pressure drops within the system are minimized. HVAC mechanics should refer to the pipe sizing table below prior to installation.
- Minimum refrigerant pipe length is 16 ft (5 m). If going less than 16 ft, coil the additional copper pipe up in horizontal loops to ensure proper oil return.
- Refrigeration grade copper tubing is the only tubing to be used. Fittings used for bends, elbow, 'P' trap, 'Y' piece, etc., must be of the wrought copper type and clean from dust, burrs, oil, etc. It is recommended that the tube is cut with a tube cutter and the entire ID is made the correct size with an expanding device after cutting. All joints in the piping must be clean and free from dust, burrs, oil, etc.
- All joints must be silver soldered with at least 10% silver content.

Minimum pipe sizes, maximum length and maximum lift

Model	Liquid Line	Suction Line	Maximum Length	Maximum Lift
HVS-24	3/8" (9.5 mm)	5/8" (15.9 mm)	164.5' (50 m)	82' (25 m)
HVS-36	3/8" (9.5 mm)	5/8" (15.9 mm)	213.25' (65 m)	98.4' (30 m)
HVS-60	3/8" (9.5 mm)	3/4 (HVS_60 = 7/8")	213.25' (65 m)	98.4' (30 m)

The HVS Variable Speed Heat Pump comes with a factory charge. Additional charge will only be needed on line sets longer than 25 ft. (See table below)

Minimum pipe sizes, factory charge and additional refrigerant required

Model	Liquid Line	Suction Line	Factory Charge (kg)	Add extra refrigerant for line sets over 25 ft (7.5 m)
HVS-24	3/8" (9.5 mm)	5/8" (15.9 mm)	5.18 lbs (2.35 kg)	1 oz/ 3 ft
HVS-36	3/8" (9.5 mm)	5/8" (15.9 mm)	6.75 lbs (3.06 kg)	1 oz/ 3 ft
HVS-60	3/8" (9.5 mm)	3/4 (HVS_60 = 7/8")	10.15 lbs (4.6 kg)	1 oz/ 3 ft

Flare Connections

When tightening flare connections on the HVS Heat Pump, refer to tightening torque and flare shape below. It is suggested to use "Nylog Blue" to seal flare connections. (If doing so, tighten to the lower end of the range of the chart below.)

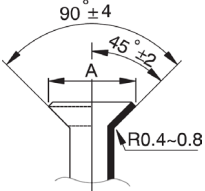
Pipe Size	Tightening Torque	Flare Dimensions (A)		Flare Shape
		Min.	Max.	
1/4"Ø (6.4 mm)	13 - 15 ft-lb (18-20 N.m.)	0.33" (8.4 mm)	0.34" (8.7 mm)	
3/8"Ø (9.5 mm)	24 - 29 ft-lb (32-39 N.m.)	0.52" (13.2 mm)	0.53" (13.5 mm)	
1/2"Ø (12.7 mm)	36 - 44 ft-lb (49-60 N.m.)	0.64" (16.2 mm)	0.65" (16.5 mm)	
5/8"Ø (15.9 mm)	42 - 52 ft-lb (57-71 N.m.)	0.76" (19.3 mm)	0.78" (19.8 mm)	
3/4"Ø (19.1 mm)	49 - 74 ft-lb (67-101N.m.)	0.91" (23.2mm)	0.93" (23.7 mm)	
7/8"Ø (22.2 mm)	63 - 81 ft-lb (85-110 N.m.)	1.04" (26.4 mm)	1.06" (26.9 mm)	

Installing Oil Traps

For proper oil return to compressor, oil traps must be installed on the suction line risers:

- Every 33 ft (10 m) when indoor unit is higher than the outdoor unit.
- Every 20 ft (6 m) when outdoor unit is higher than the indoor unit

Indoor is Higher than Outdoor

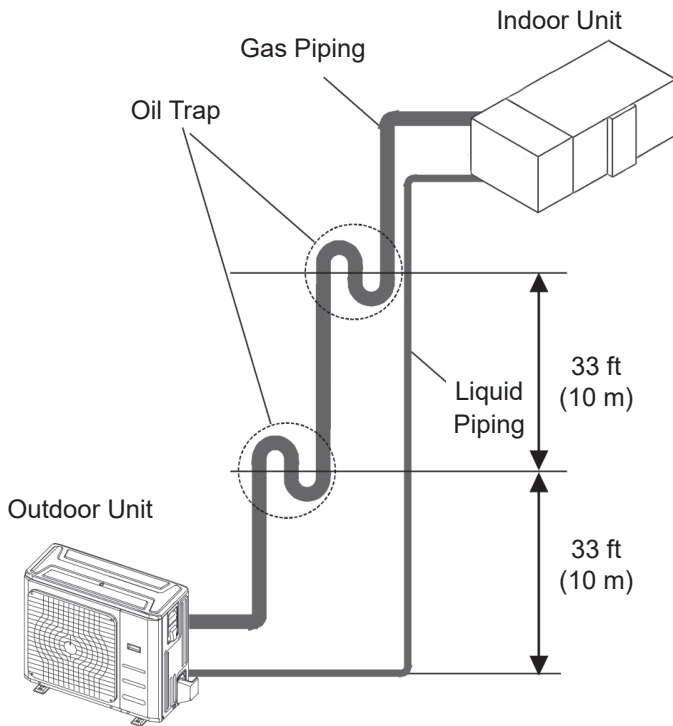

Outdoor is Higher than Indoor

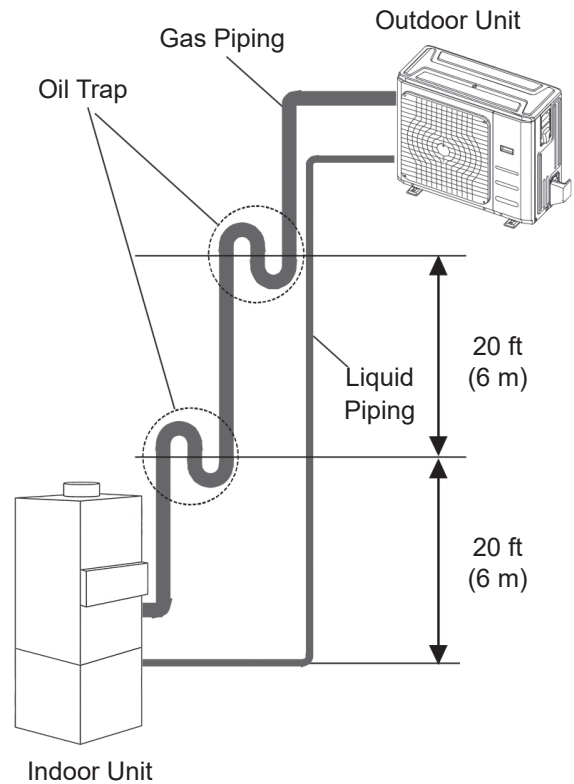

Oil Trap Detail

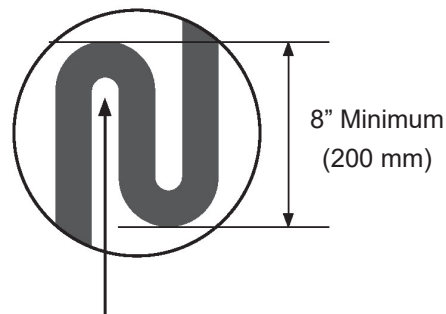

Minimum bend
radius of 6x
diameter of pipe

Interface Panel

- The interface panel is critical for indoor and outdoor unit communication.
- Field wiring shown on the wiring page is needed between the indoor unit and the interface panel, and between the interface panel and the outdoor unit using **unshielded cable on the HVS-24**, and **shielded cable on the HVS-36 & HVS-60**.

IMPORTANT

For the HVS-24 – It is critical to use unshielded communication cable (14 AWG / 4 Conductor, stranded) when running the 1, 2 and 3 communication wires between the '24v Interface Kit' and the HVS-24 outdoor unit.

For the HVS-36 & HVS-60 – It is critical to use shielded cable (18 AWG / 4 Conductor) when running the S1 and S2 communication wires between the '24v Interface Kit' and the outdoor unit.

See wiring diagrams for further details.

- Ground shielding of cable at the condenser side and cap off opposite end with a wire nut or equivalent.
- Use provided EMC magnetic ring. Wrap the communication wires around the ring twice at the '24v Interface Kit' side of the communication wires:

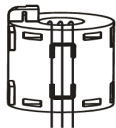
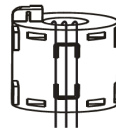
<p style="text-align: center;">EMC Magnetic Ring - HVS-24</p> <p style="text-align: center;">Wrap the electric wires 1, 2 and 3 around the magnetic ring twice</p> <div style="text-align: center;">  </div>	<p style="text-align: center;">EMC Magnetic Ring - HVS-36 & HVS-60</p> <p style="text-align: center;">Wrap the electric wires S1 and S2 (P & Q & E) around the magnetic ring twice</p> <div style="text-align: center;">  </div>
---	---

- The outdoor unit and the interface panel both require 240v supply power and require surge protection in locations with power fluctuations or inconsistencies.

NOTE: For HVS-24 the interface panel is provided with 240v via the outdoor unit. In this case, only the outdoor unit requires surge protection.

For HVS-36 and HVS-60 the interface panel and outdoor unit require separate power supplies. In this case, both need to be surge protected.

- The interface requires 24v from indoor unit (R & C).
- One temperature sensor is supplied with the interface panel which connects to T1 on the interface panel. This temperature sensor will need to be installed for the unit to operate properly and should be securely installed in the return air ductwork.

Return Air Temperature Sensor

- For the HVS variable speed heat pump to modulate correctly, the provided return air temperature sensor must be installed in the return air ductwork, just upstream from the evaporator.
- A small hole must be drilled into the return air ductwork to fit the temperature sensor in.
- This sensor should be secured using tie straps/nylon cable ties or screw mount cable ties.
- The hole drilled must be sealed back up after the sensor is screwed in the R/A ductwork.
- This T1 temperature sensor must not exceed 23' (7m) in length. This means that the interface panel must be placed within reach of the R/A ductwork just upstream from the evaporator.

Drain Fitting Installation (not provided w/ all models)

1. Fit the rubber seal on the end of the drain fitting that will connect to the outdoor unit.
2. Insert the drain fitting into the hole in the base pan of the unit (located on bottom panel of unit).
3. Rotate the drain fitting 90° until it clicks in place, facing the front of the unit.
4. Connect a drain hose extension (not provided) to the drain fitting to redirect water from the unit (if desired) during heating mode.

Important: Make sure water drains to a safe location that meets local codes and regulations and where it will not cause water damage or a slipping hazard.

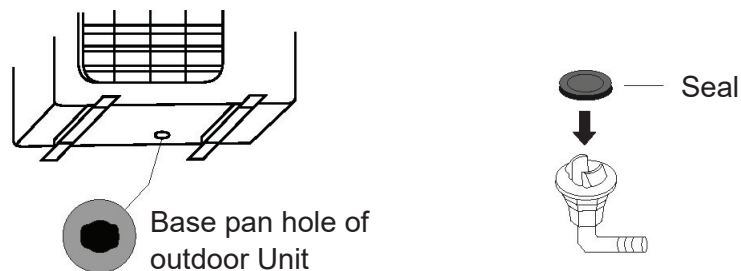

Note: Make sure water drains to a safe location that meets local codes and regulations and where it will not cause water damage or a slipping hazard.

HVS-24 Variable Speed Heat Pump Wiring

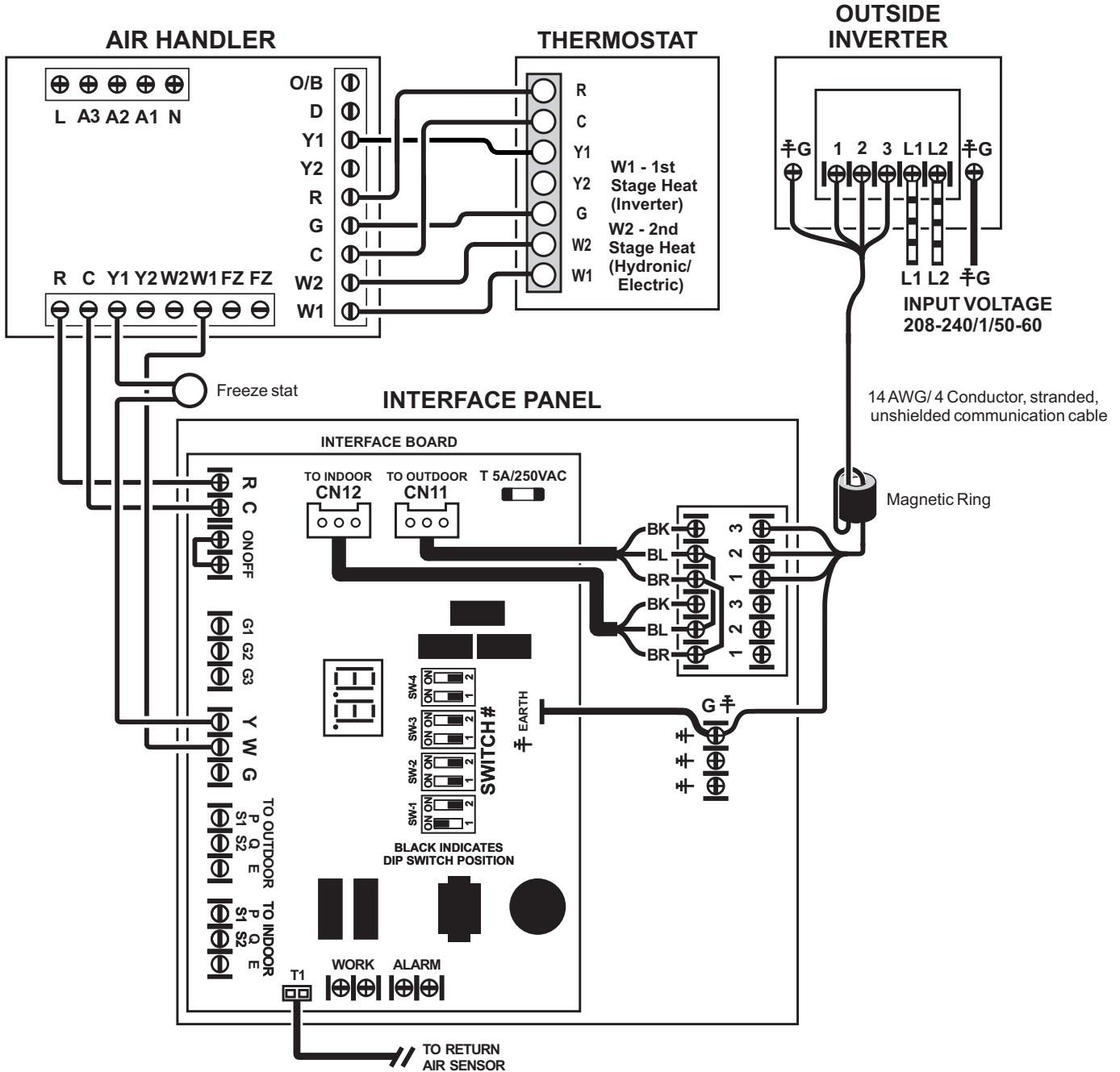

HVS24CNTL
062520

HVS-36 & HVS-60 Variable Speed Heat Pump Wiring

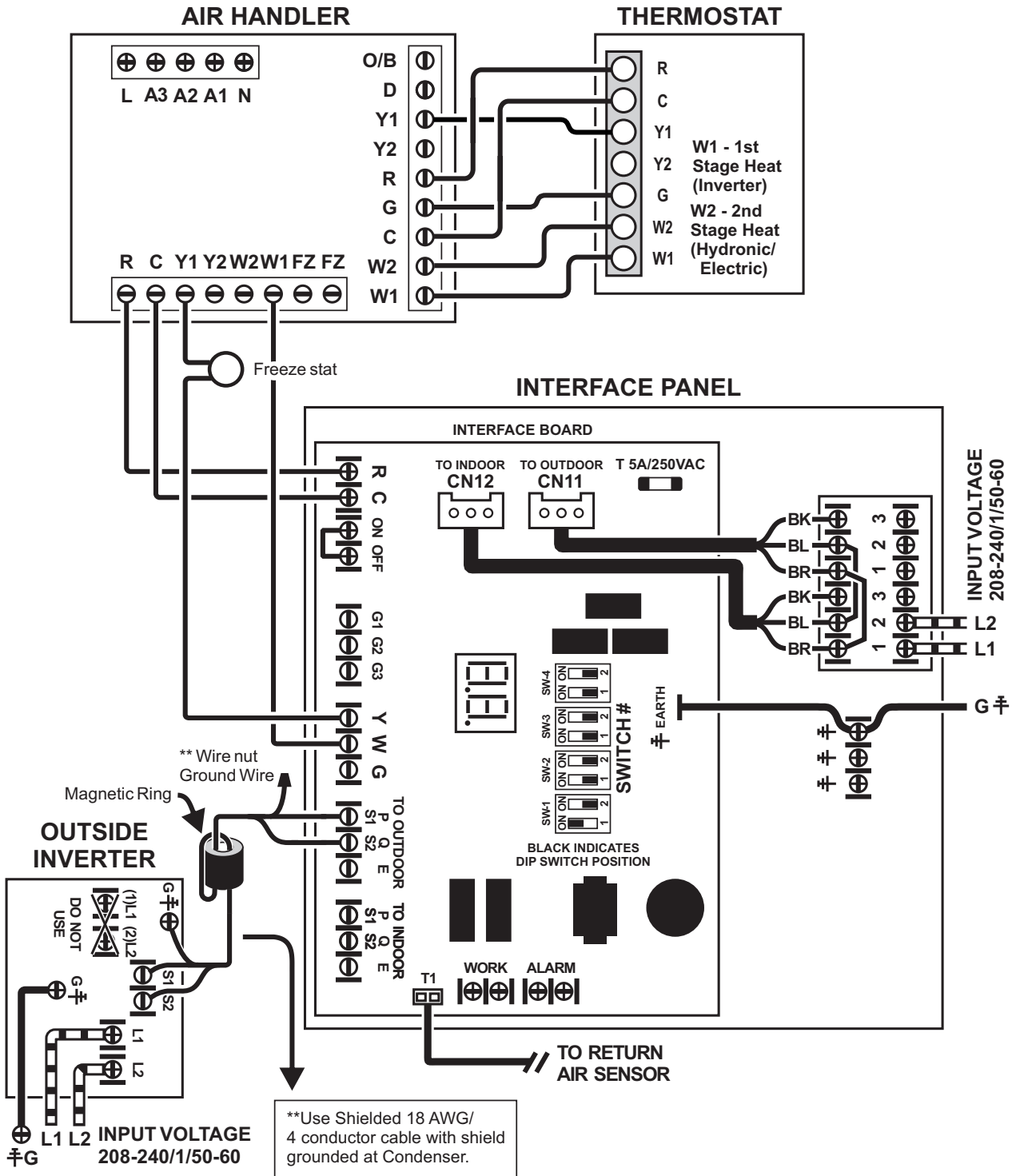

HVS36/60CNTL
062520

HVS Variable Speed Heat Pump Specifications - Dimensions

HVS-24/HVS-36

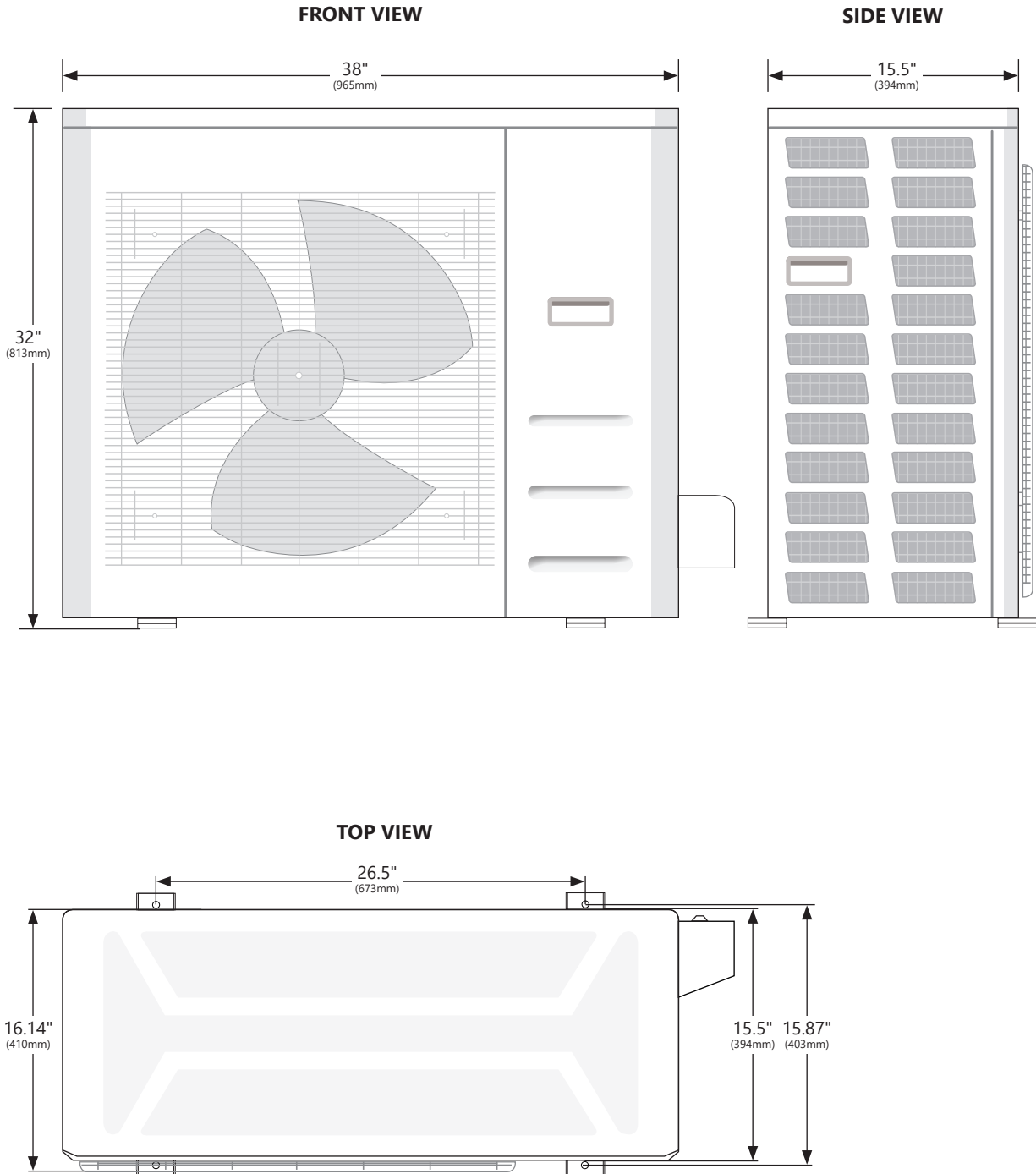

HVS Variable Speed Heat Pump Specifications - Dimensions

HVS-60

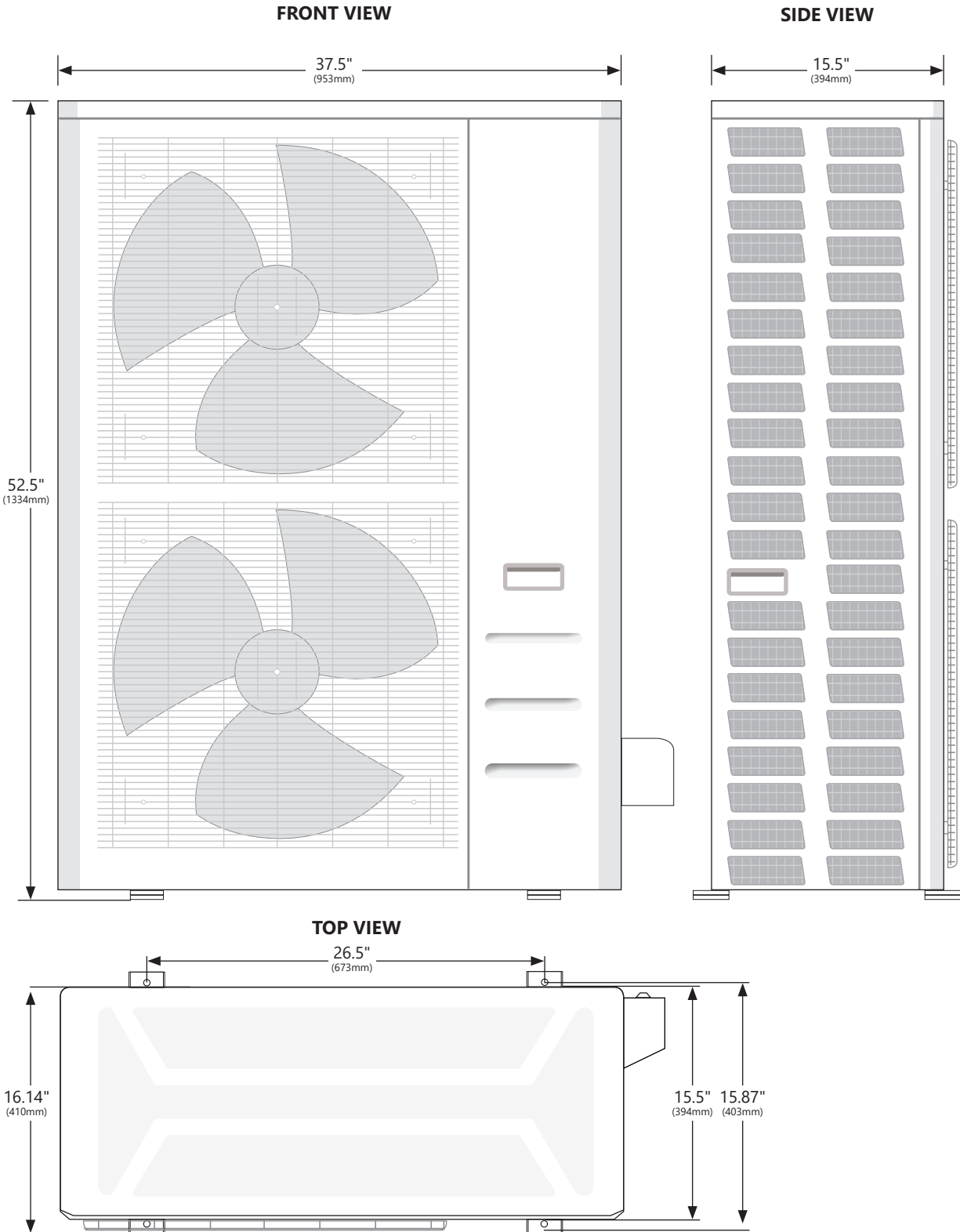

HVS Variable Speed Heat Pump Specifications



Specifications	HVS-24	HVS-36	HVS-60
Part Number	40180400002	40180400003	40180400005
Outdoor Unit Tonnage	2 Ton (7 kW)	3 Ton (10.5 kW)	5 Ton (17 kW)
Capacity Data			
Nominal Cooling Capacity ^{(1) (2)}	23,500 BTU (6.9 kW)	35,500 BTU (10.4 kW)	57,300 BTU (16.8 kW)
Operational Range (Cooling)	6,000-24,000 BTU (1.8 - 7 kW)	9,000-36,000 BTU (2.6 - 10.5 kW)	15,000-60,000 BTU (4.4 - 17.6 kW)
Nominal Heating Capacity ^{(1) (2)}	26,200 BTU (7.7 kW)	38,200 BTU (11.2 kW)	60,400 BTU (17.7 kW)
Operational Range (Heating)	6,950-27,800 BTU (2.0 - 8.1 kW)	10,325-41,300 BTU (3.0 - 12.1 kW)	15,375-61,500 BTU (4.5 - 18.0 kW)
Highest Variable Airflow	2,350 CFM (1,109 L/s)	2,500 CFM (1,180 L/s)	4,400 CFM (2,077 L/s)
Lowest Variable Airflow	400 CFM (190 L/s)	400 CFM (190 L/s)	400 CFM (190 L/s)
Electrical Data			
Power Supply	208 - 240 Volts 1 Phase - 50/60 Hz	208 - 240 Volts 1 Phase - 50/60 Hz	208 - 240 Volts 1 Phase - 50/60 Hz
Nom. Full Load Amps	17	23	26.5
Min. Circuit Ampacity	22	30	36.5
Max Fuse	30	45	50
Electrical Input Cooling (kW) ⁽¹⁾	2.0	3.25	5.3
Electrical Input Heating (kW) ⁽¹⁾	2.3	3.15	5.2
Sound Pressure (dB) (A) @ 1m	61	62	63
Soft Starter	Variable Frequency		
Dimensions - Outdoor Unit			
Dimensions (L x W x H)	38" x 16.14" x 32" (965mm x 410mm x 813mm)	38" x 16.14" x 32" (965mm x 410mm x 813mm)	37.5" x 16.25" x 52.5" (953mm x 413mm x 1,334mm)
Weight	155 lbs (70.3 kg)	155 lbs (70.3 kg)	269 lbs (122 kg)

(1) Capacities are based on A.S.3823.12

(2) Capacity modulation is extended by variable indoor airflow. Actual percentage loading will vary depending on application.

DESIGN CONDITIONS:

Cooling 35°C (95°F) DB Outdoor / 27°C (80°F) DB, 19°C (66°F) WB Air Entering Indoor Unit

Heating 7°C (44°F) DB, 6°C (43°F) WB Outdoor/ 21°C (70°F) DB Air Entering Indoor Unit

Nominal Operating Range -10°C (14°F) WB to 50°C (122°F) DB

Sound pressure level is influenced by the surroundings, therefore it may vary upon location.

Features:

- Variable Speed Compressor allows for Zoning with True Efficiency
- 2, 3 or 5 Ton Cooling Capacity
- Easy Installation
- Energy Efficient Zoning
- Patented Interface allows Integration with 3rd Party Air Handlers

Energy Saving Products Ltd, established in 1983, manufactures the Hi-Velocity Systems™ product line for residential, commercial and multi-family markets. Our facilities house Administration, Sales, Design, Manufacturing, as well as Research & Development complete with an in-house test lab. Energy Saving Products prides itself on Customer Service and provides design services and contractor support.

For all of your Heating, Cooling and Indoor Air Quality needs, the Hi-Velocity System is the right choice for you!



Small Duct Heating, Cooling and IAQ Systems

Build Smart, Breathe *Easy*

Hi-Velocity HE-Z Air Handlers, *Green* Technology



Phone: 780-453-2093
Fax: 780-453-1932
Toll Free: 1-888-652-2219

www.hi-velocity.com